

# ePAPER 2.0" - 172X72 DOTS

**INCL. CONTROLLER SSD1606 WITH SPI**

*available ex stock in low  
quantities !*

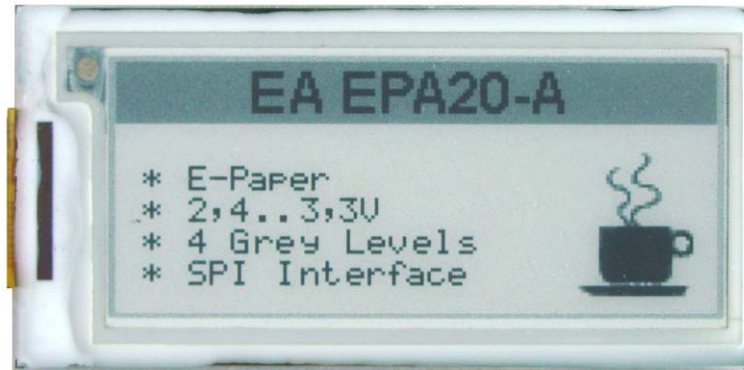

*Dimensions:  
59.2 x 29.2 mm*

## TECHNICAL DATA

- \* HIGH-CONTRAST E-PAPER LCD DISPLAY
- \* WIDE VIEWING ANGLE
- \* ACTIVE MATRIX ELECTROPHORETIC DISPLAY (ePAPER) 2" WITH 172X72 DOTS
- \* CONTROLLER SSD1606 FOR SPI (4-WIRE) INTERFACE
- \* POWER: +3,3V SINGLE SUPPLY
- \* NO ADDITIONAL VOLTAGES REQUIRED
- \* OPERATING TEMPERATURE RANGE 0°...+50°C (STORAGE TEMP. -25°...+75°C)
- \* STANDBY-POWER 0W (CONTENT READABLE)
- \* POWER CONSUMPTION WHILE CONTENT CHANGE ca. 40 mW (~1 sec image update)
- \* ON-CHIP DISPLAY RAM
- \* ON-CHIP BOOSTER AND REGULATOR FOR GATE AND SOURCE VOLTAGES
- \* 4 GRAYSCALES - BLACK, DARK GRAY, LIGHT GRAY AND WHITE

## ORDERING CODE

ePAPER DISPLAY 2" 172X72

**EA EPA20-A**

## ACCESSORIES

ZIFF-CONNECTOR, 24 PINS, TOP CONTACT

**EA WF050-24T**

**APPLICATION EXAMPLE**

Please find a sample schematic below.

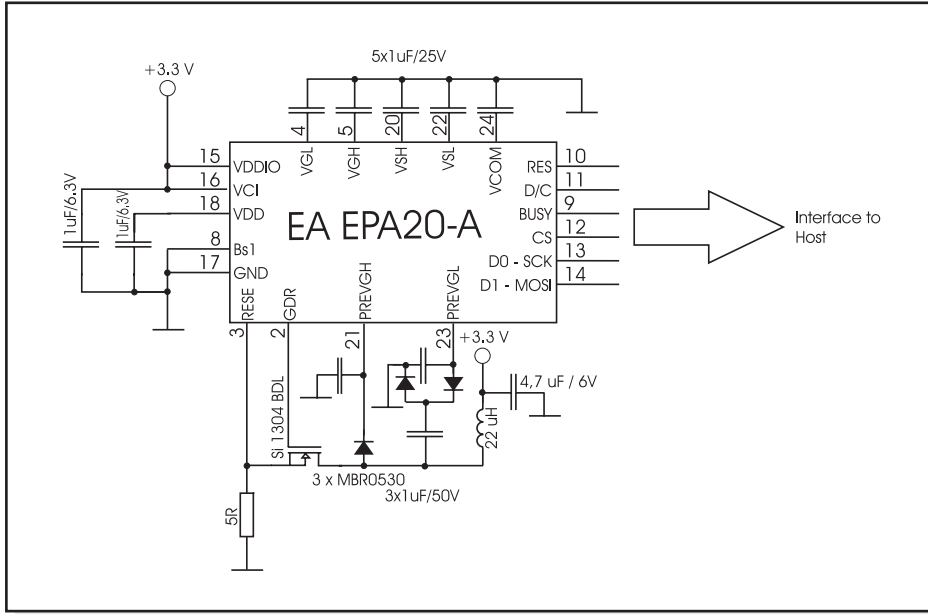

**INITIALISATION EXAMPLE**

```
const unsigned char lut_data [] =
{
    0x82, 0x00, 0x00, 0x00, 0xAA, 0x00, 0x00, 0x00, 0xAA,
    0xAA, 0x00, 0x00, 0xAA, 0xAA, 0xAA, 0x00, 0x55, 0xAA,
    0xAA, 0x00, 0x55, 0x55, 0x55, 0x55, 0xAA, 0xAA, 0xAA,
    0xAA, 0x55, 0x55, 0x55, 0x55, 0xAA, 0xAA, 0xAA, 0xAA,
    0x15, 0x15, 0x15, 0x15, 0x05, 0x05, 0x05, 0x05, 0x01,
    0x01, 0x01, 0x01, 0x00, 0x00, 0x00, 0x00, 0x00, 0x00,
    0x00, 0x00, 0x00, 0x00, 0x00, 0x00, 0x00, 0x00, 0x00,
    0x00, 0x00, 0x00, 0x00, 0x00, 0x00, 0x00, 0x00, 0x00,
    0x00, 0x00, 0x00, 0x00, 0x00, 0x00, 0x00, 0x00, 0x41,
    0x45, 0xF1, 0xFF, 0x5F, 0x55, 0x01, 0x00, 0x00, 0x00
};
```

```
void SPI_out (unsigned char data)
{
    uchar count;
    CS=0;
    for(count=0;count<8;count++)
    {
        if (data&0x80)
            SDIN=1;
        else
            SDIN=0;
        SCLK=1;
        data<<=1;
        SCLK=0;
    }
    CS=1;
}
```

```
void writcmd(char data)
{
    DC=0;
    SPI_out (data);
}
```

```
void writedata(char data)
{
    DC=1;
    SPI_out (data);
}
```

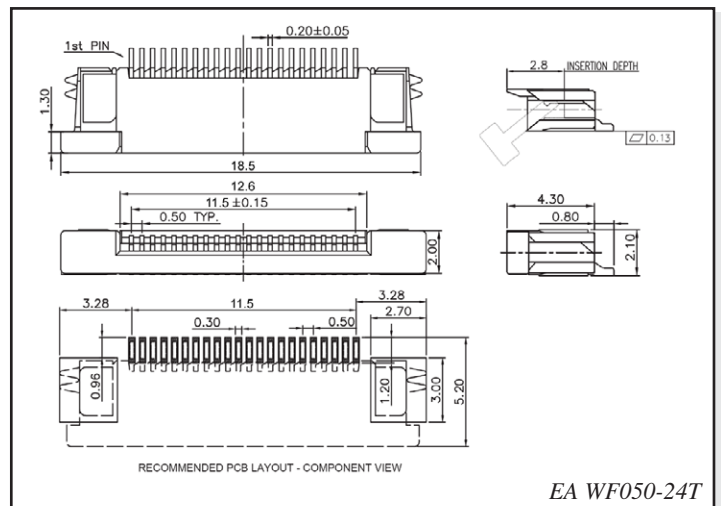

```
void init(void)
{
    unsigned char i;

    CS=1;           //perform reset CS idle=1
    SCLK=0;        //SCLK idle=0
    RST=1;
    delaysms(1);
    RST=0;
    delaysms(2);
    RST=1;
    delaysms(3);

    writecmd(0x10); //do not enter deep sleep mode
    writedata(0x00);

    writecmd(0x11); //data entry mode setting,0x01,Y decrement,X increment
    writedata(0x01);
    writecmd(0x44); //set RAM X-address start/end position
    writedata(0x00); //RAM X -address start at 00H
    writedata(0x11); //RAM X-address end at 11H->(17D),that is (17+1*4=72)start/end
                    //position
    writedata(0xAB); //RAM Y-address start at ABH->(171D)
    writedata(0x00); //RAM Y-address end at 00H
    writecmd(0x4E); //set RAM x address count to 0;
    writedata(0x00);
    writecmd(0x4F); //set RAM Y address count to 172->0;
    writedata(0xAB);

    writecmd(0xF0); //booster feedback selection,0x1F->internal feedback is used
    writedata(0x1F); //0x83
    writecmd(0x21); //bypass the RAM data into the display,enable pass
    writedata(0x03);
    writecmd(0x2C); //write VCOM register
    writedata(0xA0);
    writecmd(0x3C); //board waveform, board voltage
    writedata(0x63);
    writecmd(0x22); //enable sequence, CLK->CP->
    writedata(0xC4);

    writecmd(0x32); //write LUT register
    for(i=0;i<90;i++)
        writedata(lut_data[i]);
}

void fill_display(uchar dat) //0xFF=white, 0x00=black, 0x55=gray 1, 0xAA=gray 2
{
    unsigned int i;

    writecmd(0x24); //data write into RAM after this command

    for(i=0;i<3096;i++) //3096 = 172x72/8x2, (2-Bit per dot)
    {
        writedata(dat);
    }
    writecmd(0x20);

    //Booster diable
    writecmd(0x22); //display update sequence option ,in page 33
    writedata(0x02);
    writecmd(0x20);
}
}
```

Further details concerning the command set and electrical specifications are mentioned in the controller's datasheet SSD1606:

[http://www.lcd-module.de/eng/pdf/zubehoer/ssd1606\\_1\\_1.pdf](http://www.lcd-module.de/eng/pdf/zubehoer/ssd1606_1_1.pdf)

## DIMENSIONS

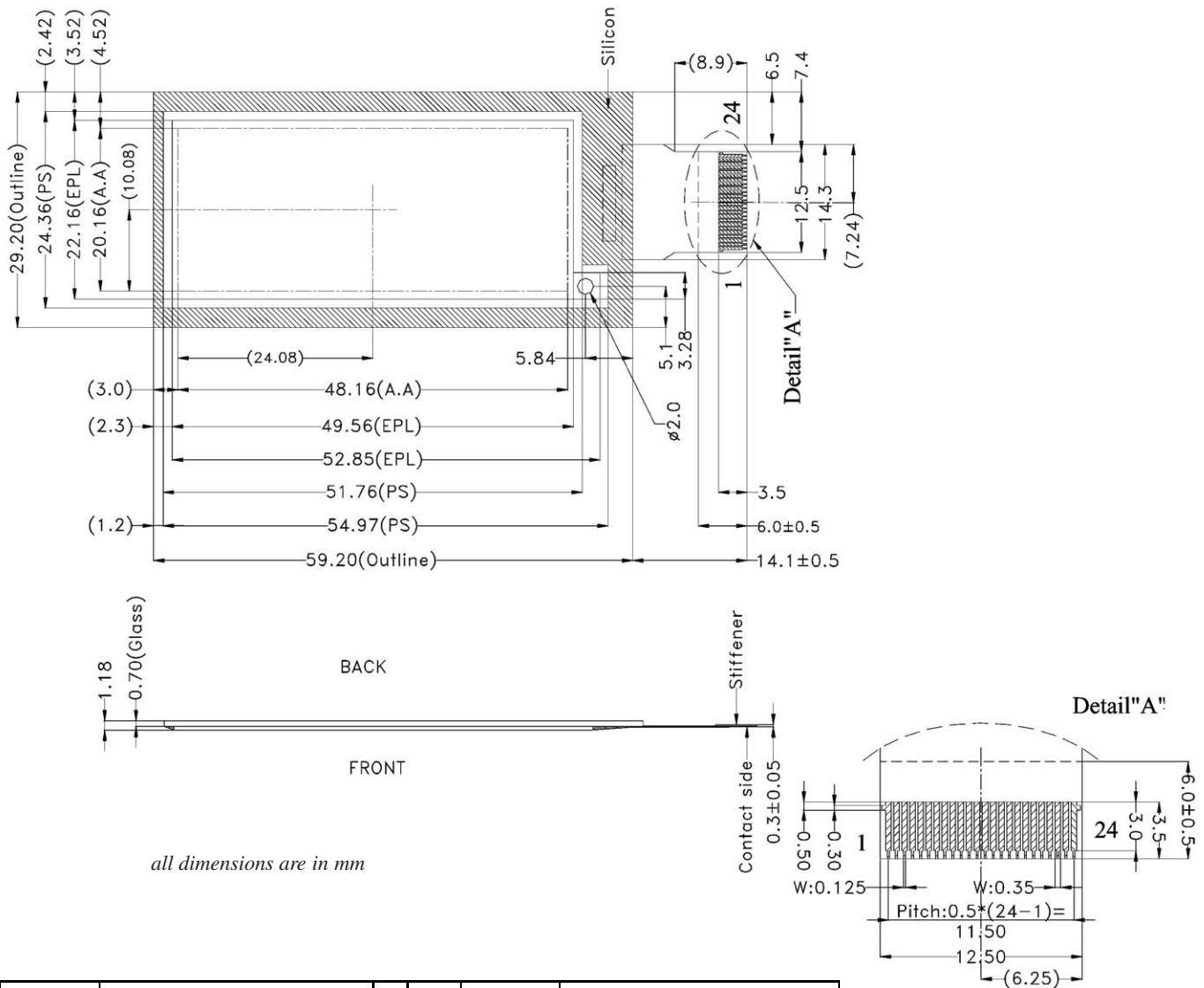

Pin	Symbol	Function
1	NC	do not connect
2	GDR	Gate drive control
3	RESE	current sense input
4	VGL	negative gate driving voltage
5	VGH	positive gate driving voltage
6	TACL	°C digital temp. sensor clock
7	TSDA	°C digital temp. sensor data
8	BS1	Bus selector pin
9	BUSY	Busy state output pin
10	!RES	Reset (active low)
11	D!/C	data (high)/command (low) control
12	!CS	Chip select (active low)

Pin	Symbol	Function
13	D0	SPI-Clock (SCK)
14	D1	SPI-Data (MOSI)
15	VDDIO	Power for I/O logic pins
16	VCI	Power for display driver chip
17	GND	Ground
18	VDD	Power supply
19	VPP	Power for OTP programming
20	VSH	positive source driving voltage
21	PREVGH	power supply for VGH and VSH
22	VSL	negative source driving voltage
23	PREVGL	Power supply for VCOM, VGL, VSL
24	VCOM	VCOM driving voltage

Note:

- The display's surface is covered with a protecting foil. Please remove.
- Handle with care. Slim glas