



## SPECIFICATIONS

CUSTOMER	:	PTC
SAMPLE CODE	:	SH102600T003-IBA
MASS PRODUCTION CODE	:	PH102600T003-IBA
SAMPLE VERSION	:	01
SPECIFICATIONS EDITION	:	001
DRAWING NO. (Ver.)	:	LMD-PH102600T003-IBA (Ver.001)
PACKAGING NO. (Ver.)	:	PKG-PH102600T003-IBA (Ver.001)

**Customer Approved**

Date:

Approved	Checked	Designer
黃秋源 Oliver Huang	李健弘 Lambert Lee	黃俊清 Ackey Huang

- Preliminary specification for design input  
 Specification for sample approval

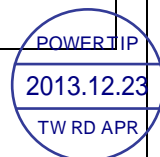

## POWERTIP TECH. CORP.

**Headquarters:** No.8, 6<sup>th</sup> Road, Taichung Industrial Park,  
Taichung, Taiwan  
台中市 407 工業區六路 8 號

TEL: 886-4-2355-8168  
FAX: 886-4-2355-8166

E-mail: [sales@powertip.com.tw](mailto:sales@powertip.com.tw)  
[Http://www.powertip.com.tw](http://www.powertip.com.tw)



## Contents

### 1. SPECIFICATIONS

- 1.1 Features
- 1.2 Mechanical Specifications
- 1.3 Absolute Maximum Ratings
- 1.4 DC Electrical Characteristics
- 1.5 Optical Characteristics
- 1.6 Backlight Characteristics

### 2. MODULE STRUCTURE

- 2.1 Counter Drawing
- 2.2 Interface Pin Description
- 2.3 Timing Characteristics

### 3. QUALITY ASSURANCE SYSTEM

- 3.1 Quality Assurance Flow Chart
- 3.2 Inspection Specification

### 4. RELIABILITY TEST

- 4.1 Reliability Test Condition

### 5. PRECAUTION RELATING PRODUCT HANDLING

- 5.1 Safety
- 5.2 Handling
- 5.3 Storage
- 5.4 Terms of Warranty

Appendix : LCM Drawing  
LCM Packaging Specifications

## 1. SPECIFICATIONS

### 1.1 Features

#### Main LCD Panel

Item	Standard Value
Display Type	1024* (R、G、B) * 600 Dots
LCD Type	Normally white
Screen size(inch)	10.1(Diagonal)
Surface treatment	Anti-glare, Hard-Coating(3H)
Color configuration	R.G.B. vertical stripe
Backlight	White LED
Interface	LVDS
ROHS	THIS PRODUCT CONFORMS THE ROHS OF PTC Detail information please refer website : <a href="http://www.powertip.com.tw/news.php?area_id_view=1085560481/">http://www.powertip.com.tw/news.php?area_id_view=1085560481/</a>

### 1.2 Mechanical Specifications

Item	Standard Value	Unit
Outline Dimension	244.0(W) * 143.0 (L) * 12.4 (H)	mm

#### LCD panel

Item	Standard Value	Unit
Active Area	222.72 (W) * 125.28 (L)	mm

Note : For detailed information please refer to LCM drawing

### 1.3 Absolute Maximum Ratings

#### Module

Item	Symbol	Min.	Max.	Unit	
Supply Voltage	$V_{IN}$	-0.3	3.6	V	Logic power supply voltage
		-0.3	24	V	LED Driver Vin
Power Supply Fuse Current Setting	$I_{FUSE}$	-	1.5	A	Vin from 10%~90%,rise time 500us
Input Signal	$V_S$	-	3.6	V	LVDS signals
PWM Voltage	$V_{PWM}$	0.8	5.0	V	PWM Dimming Voltage
Operating Temperature	TOP	-30	85	°C	(1)
Operating Humidity	HOP	10	85	%RH	
Storage Temperature	TST	-30	85	°C	
Storage Humidity	HST	10	85	%RH	

Note:

(1) The storage /operating temperature. Maximum Wet-Bulb should be 39 degree C. There is no condensation on the panel surface.

## 1.4 DC Electrical Characteristics

### System Power Supply

ITEM	SYMBOL	MIN.	TYP.	MAX.	UNIT	CONDITIONS
Input Power Supply Voltage	$V_{IN}$	3.0	3.3	3.6	V	
Input Power Supply Current	$I_{VIN}$	-	-	191	mA	Black pattern 60Hz
Input Inrush Current	$I_{RUSH}$	-	-	1.5	A	0.5ms rise time(10%~90%)
Input Power Voltage Ripple	$V_{RPL}$	-	-	200	mV	$V_{P-P}$
REV	VH	2.0	3.3	5.0	V	-
	VL	-	-	0.8	V	-

### LED Power Supply

ITEM	SYMBOL	MIN.	TYP.	MAX.	UNIT	CONDITIONS
Input Power Supply Voltage	$V_{LED-IN}$	8	12	16	V	
Input Power Supply Current	$I_{IN}$	-	-	546	mA	
EN/PWM	VH	2.0	3.3	5.0	V	
	VL	-	-	0.8	V	

### LVDS Signals

ITEM	SYMBOL	MIN.	TYP.	MAX.	UNIT	CONDITIONS
Differential Input High Threshold	$V_{th}$	-	-	+100	mV	$V_{cm}=+1.2v$
Differential Input High Threshold	$V_{tl}$	-100	-	-	mV	$V_{cm}=+1.2v$
Magnitude Differential Input Voltage	$ V_{id} $	200	-	600	mV	
Common Mode Voltage	$V_{cm}$	1.0	1.2	1.4	V	$V_{th} - V_{tl} = 200mV$
Common Mode Voltage Offset	$\Delta V_{cm}$	-50	-	+50	mV	$V_{th} - V_{tl} = 200mV$

## 1.5 Optical Characteristics

### TFT LCD Panel

VDD=3.3V, Ta=25°C

Item	Symbol	Condition	Min.	Typ.	Max.	Unit	-	
Response time	Tr + Tf	Ta = 25°C θX, θY = 0°	-	16	20	ms	Note2	
Viewing angle	Top	θY+	CR ≥ 10	70	80	-	Deg.	Note4
	Bottom	θY-		70	80	-		
	Left	θX-		70	80	-		
	Right	θX+		70	80	-		
Contrast ratio	CR		400	500	-	-	Note3	
Color of CIE Coordinate (With B/L )	White	X	Ta = 25°C θX, θY = 0°	0.255	0.305	0.355	-	Note1
		Y		0.275	0.325	0.375		
	Red	X		0.529	0.579	0.629		
		Y		0.294	0.344	0.394		
	Green	X		0.276	0.326	0.376		
		Y		0.541	0.591	0.641		
	Blue	X		0.109	0.159	0.209		
		Y		0.081	0.131	0.181		
Average Brightness Pattern=white display	IV	-	400	500	-	cd/m <sup>2</sup>	Note1	
Uniformity	B	-	75	-	-	%	Note1	

Note1:

1 :  $B = B(\min) / B(\max) \times 100\%$

2 : Measurement Condition for Optical Characteristics:

a : Environment: 25 ±5 / 60±20%R.H , no wind , dark room below 10 Lux at typical lamp current and typical operating frequency.

b : Measurement Distance: 500 ± 50 mm , (θ= 0°)

c : Equipment: TOPCON BM-7 fast , (field 1°) , after 10 minutes operation.

d : The uncertainty of the C.I.E coordinate measurement ±0.01 , Average Brightness ± 4%

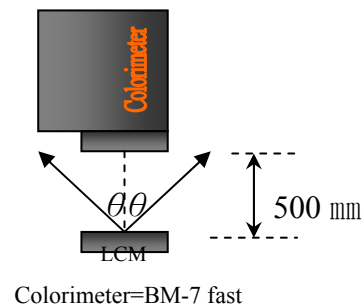
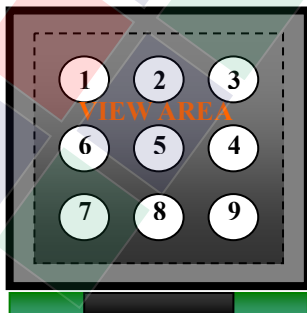

**Note2: Definition of response time:**

The output signals of photo detector are measured when the input signals are changed from "black" to "white"(falling time) and from "white" to "black"(rising time), respectively. The response time is defined as the time interval between the 10% and 90% of Amplitudes.

Refer to figure as below:

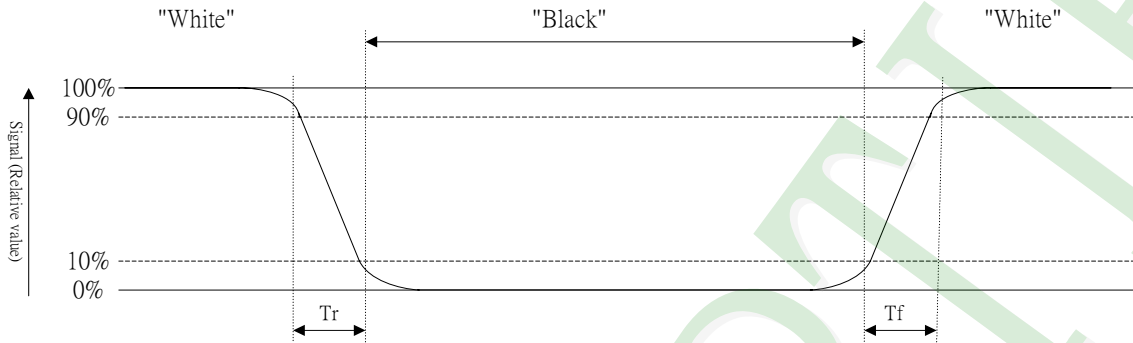

**Note3: Definition of contrast ratio:**

Contrast ratio is calculated with the following formula

$$\text{Contrast ratio (CR)} = \frac{\text{Photo detector output when LCD is at "White" state}}{\text{Photo detector output when LCD is at "Black" state}}$$

**Note4: Definition of viewing angle:**

Refer to figure as below:

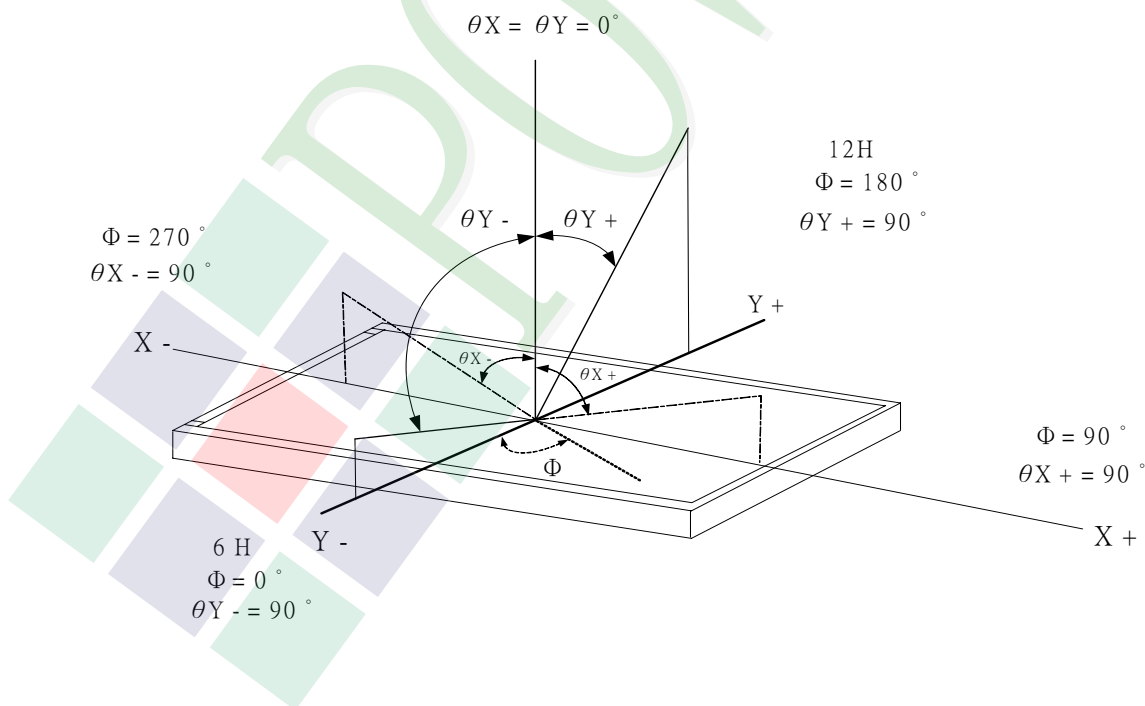



## 1.6 Backlight Characteristics

Item	UNIT	MIN	TYP	MAX	CONDITION	
VIN_LED	V	8	12	16	DUTY=100%	
V <sub>VIN_LED</sub>	mA	-	-	543	-	
F <sub>DIM</sub>	HZ	100	-	1K	-	
DUTY	%	5	-	100	-	
CTRL	VIH	V	2	3.3	5	-
	VIL	V	0	-	0.8	-
V <sub>OUT</sub>	V	-	22.4	-	-	
I <sub>OUT</sub>	mA	-	160	-	-	
L <sub>T</sub>	Hours	50,000	-	-	LED Life Time	

Note : The LED life time define as the estimated time to 50% degradation of initial luminous.

## 2. MODULE STRUCTURE

### 2.1 Counter Drawing

#### 2.1.1 LCM Mechanical Diagram

\* See Appendix

#### 2.1.2 Block Diagram

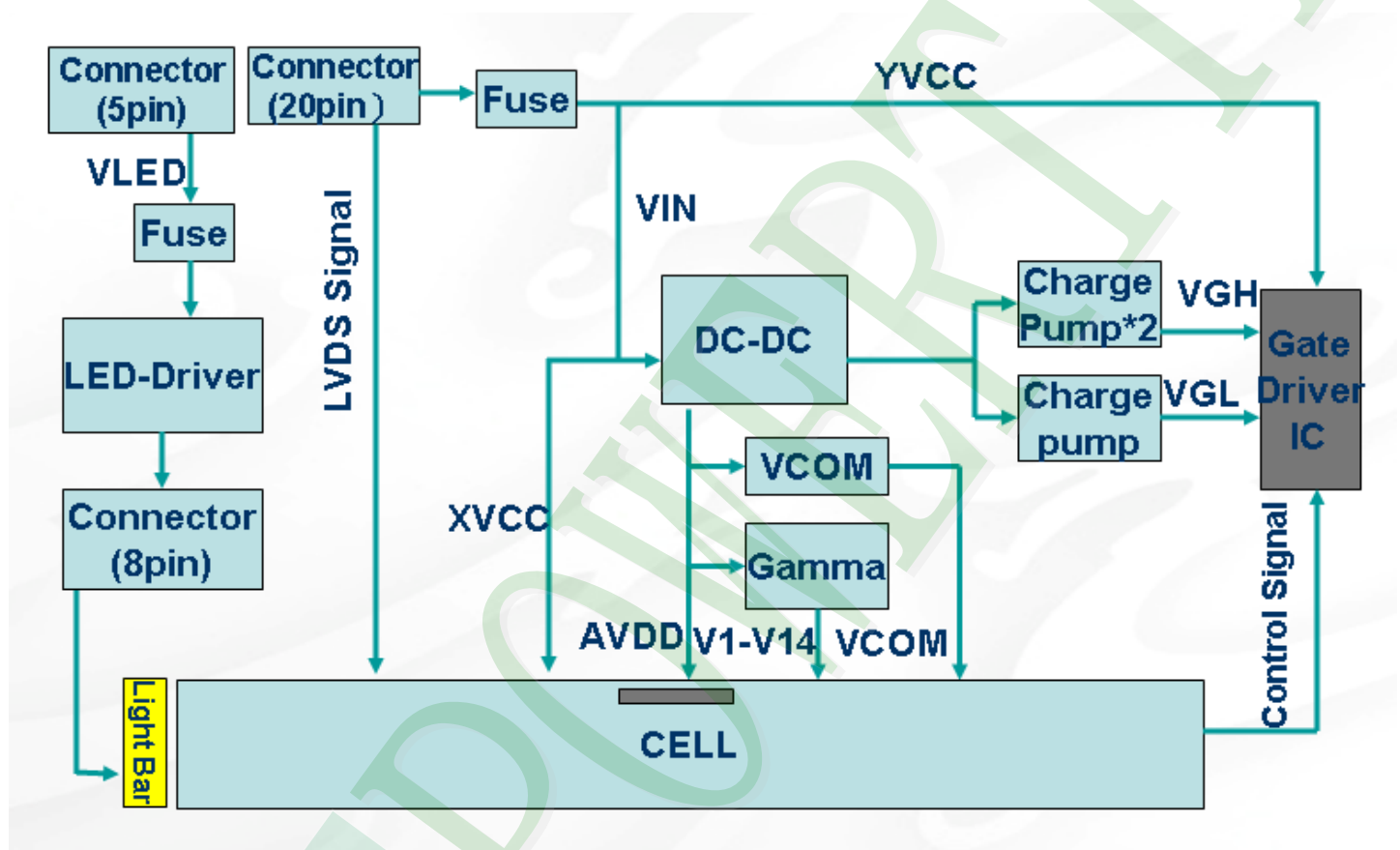

## 2.2 Interface Pin Description(CN1)

Pin No.	Symbol	Description	
1	VDD	Power Supply.3.3V (typical)	-
2	VDD	Power Supply.3.3V (typical)	-
3	VSS	Ground.	-
4	REV	Reverse Scan selection.	-
5	Rin 1-	-LVDS differential data input..	-
6	Rin 1+	+LVDS differential data input..	-
7	VSS	Ground.	-
8	Rin 2-	-LVDS differential data input.	-
9	Rin 2+	+LVDS differential data input.	-
10	VSS	Ground.	-
11	Rin 3-	-LVDS differential data input.	-
12	Rin 3+	+LVDS differential data input.	-
13	VSS	Ground.	-
14	ClkIN-	-LVDS differential data input.	-
15	ClkIN+	+LVDS differential data input.	-
16	VSS	Ground.	-
17	NC	Not connection.	-
18	NC	Not connection.	-
19	VSS	Ground.	-
20	NC	Not connection.	High Active

**B/L Pin Assignment(CN2)**

Pin No.	Symbol	Description	Remarks
1	VCC	Power Supply. 12V(typical).	-
2	GND	Ground.	-
3	EN	3.3V (typical)	-
4	PWM	3.3V (typical)	-
5	NC	Not Connection	-

## 2.3 Timing Characteristics

### DE Synchronization

Parameter	Symbol	Unit	Min.	Typ.	Max.
LVDS Clock Frequency <single>	$f_{dck}$	MHz	45	51.2	57
H Total Time	$T_{hp}$	clocks	1,324	1,344	1,364
H Active Time	HA	clocks	1,024	1,024	1,024
H Blanking Time	$TH_{BLANK}$	clocks	300	320	340
V Total Time	$T_{vp}$	lines	625	635	645
V Active Time	VA	lines	600	600	600
V Blanking Time	$TV_{BLANK}$	lines	25	35	45
V Frequency	$f_v$	Hz	55	60	65

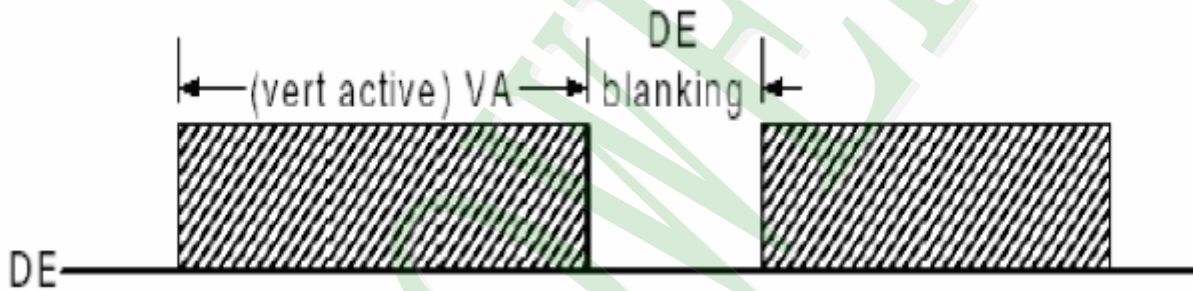

### LVDS Data Mapping



### 3. QUALITY ASSURANCE SYSTEM

#### 3.1 Quality Assurance Flow Chart

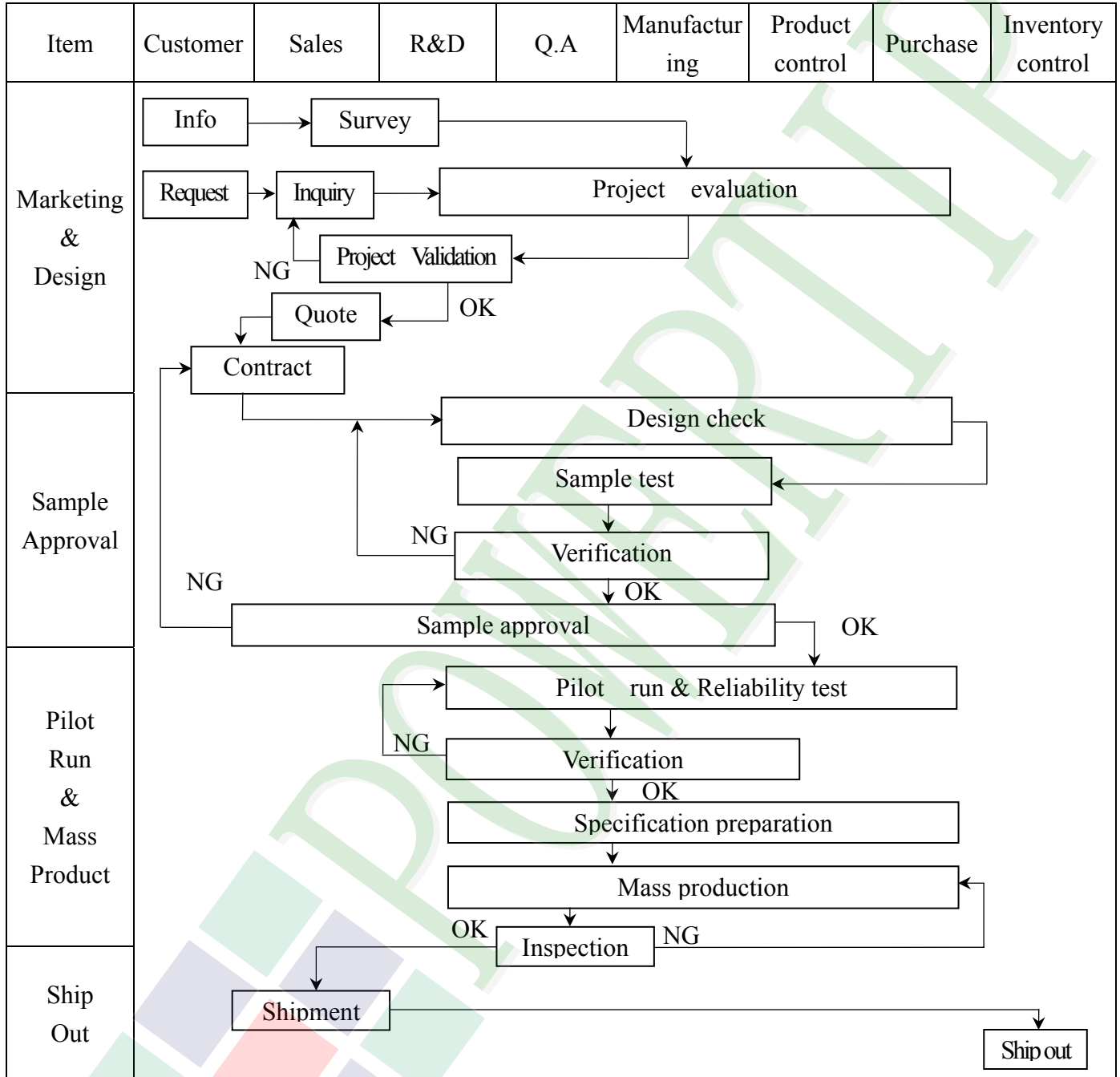

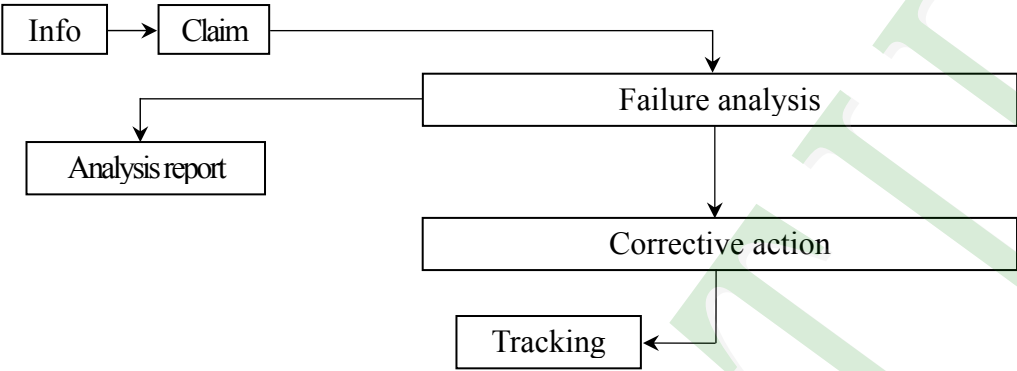
Item	Customer	Sales	R&D	Q.A	Manufacturing	Product control	Purchase	Inventory control
Sales Service	 <pre> graph TD     Info[Info] --&gt; Claim[Claim]     Claim --&gt; Failure[Failure analysis]     Claim --&gt; Report[Analysis report]     Failure --&gt; Action[Corrective action]     Action --&gt; Tracking[Tracking]         </pre>							
Q.A Activity	1. ISO 9001 Maintenance Activities 3. Equipment calibration 5. Standardization Management				2. Process improvement proposal 4. Education And Training Activities			

### 3.2. Inspection Specification

Scope : The document shall be applied to TFT-LCD Module for 3.5" ~10.1" (Ver.B01).

Inspection Standard : MIL-STD-105E Table Normal Inspection Single Sampling Level .

Equipment : Gauge 、 MIL-STD 、 Powertip Tester 、 Sample

Defect Level : Major Defect AQL : 0.4 ; Minor Defect AQL : 1.5

OUT Going Defect Level : Sampling.

Standard of the product appearance test :

a. Manner of appearance test :

- (1). The test best be under 20W×2 fluorescent light , and distance of view must be at 30 cm.
- (2). The test direction is base on about around 45° of vertical line.

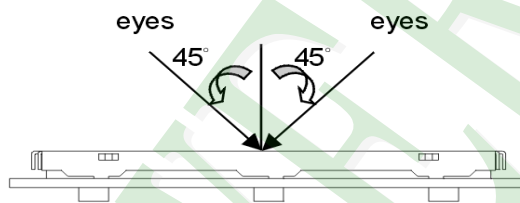

(3). Definition of area.

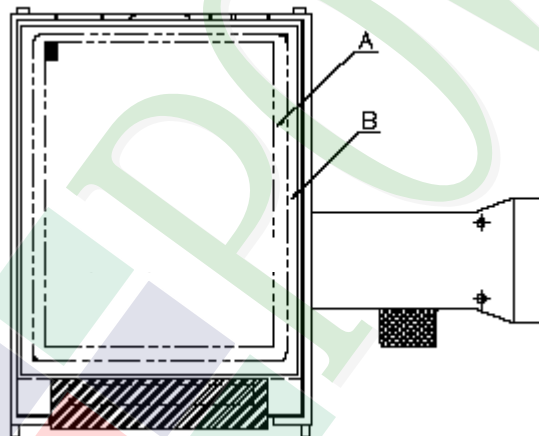

**A area** : viewing area

**B area** : Outside of viewing area

(4). Standard of inspection : (Unit : mm)



◆Specification For TFT-LCD Module 3.5" ~10.1" :

(Ver.B01)

NO	Item	Criterion	Level										
01	Product condition	1.1 The part number is inconsistent with work order of production.	Major										
		1.2 Mixed product types.	Major										
		1.3 Assembled in inverse direction.	Major										
02	Quantity	2.1 The quantity is inconsistent with work order of production.	Major										
03	Outline dimension	3.1 Product dimension and structure must conform to structure diagram.	Major										
04	Electrical Testing	4.1 Missing line character and icon.	Major										
		4.2 No function or no display.	Major										
		4.3 Display malfunction.	Major										
		4.4 LCD viewing angle defect.	Major										
		4.5 Current consumption exceeds product specifications.	Major										
05	Dot defect (Bright dot、Dark dot) On -display	<table border="1"> <thead> <tr> <th>Item</th> <th>Acceptance (Q'ty)</th> </tr> </thead> <tbody> <tr> <td>Bright Dot</td> <td>4</td> </tr> <tr> <td>Dark Dot</td> <td>5</td> </tr> <tr> <td>Joint Dot</td> <td>3</td> </tr> <tr> <td>Total</td> <td>7</td> </tr> </tbody> </table>	Item	Acceptance (Q'ty)	Bright Dot	4	Dark Dot	5	Joint Dot	3	Total	7	Minor
		Item	Acceptance (Q'ty)										
		Bright Dot	4										
		Dark Dot	5										
		Joint Dot	3										
Total	7												
5.1 Inspection pattern : full white , full black , Red , Green and blue screens.													
5.2 It is defined as dot defect if defect area > 1/2 dot.													
5.3 The distance between two dot defect $\geq 5$ mm.													
5.4 Bright dot that can be seen through 5% ND filter.													

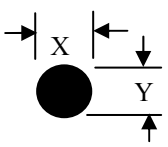
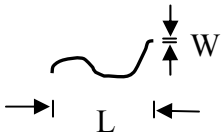
NO	Item	Criterion	Level																																					
06	<p><b>Black or white dot、scratch、contamination</b></p> <p><b>Round type</b></p>  <p><math>\Phi = (x + y) / 2</math></p> <p><b>Line type</b></p> 	<p><b>6.1 Round type ( Non-display or display ) :</b></p> <table border="1" data-bbox="526 436 1308 862"> <thead> <tr> <th rowspan="2">Dimension (diameter : <math>\Phi</math>)</th> <th colspan="2">Acceptance (Q'ty)</th> </tr> <tr> <th>A area</th> <th>B area</th> </tr> </thead> <tbody> <tr> <td><math>\Phi \ 0.25</math></td> <td>Ignore</td> <td rowspan="3">Ignore</td> </tr> <tr> <td><math>0.25 &lt; \Phi \ 0.50</math></td> <td>5</td> </tr> <tr> <td><math>\Phi &gt; 0.50</math></td> <td>0</td> </tr> <tr> <td>Total</td> <td>5</td> <td></td> </tr> </tbody> </table> <p><b>6.2 Line type( Non-display or display ) :</b></p> <table border="1" data-bbox="502 974 1332 1444"> <thead> <tr> <th rowspan="2">Length (L)</th> <th rowspan="2">Width (W)</th> <th colspan="2">Acceptance (Q'ty)</th> </tr> <tr> <th>A area</th> <th>B area</th> </tr> </thead> <tbody> <tr> <td>---</td> <td><math>W \ 0.03</math></td> <td>Ignore</td> <td rowspan="5">Ignore</td> </tr> <tr> <td><math>L \ 10.0</math></td> <td><math>0.03 &lt; W \ 0.05</math></td> <td>4</td> </tr> <tr> <td><math>L \ 5.0</math></td> <td><math>0.05 &lt; W \ 0.10</math></td> <td>2</td> </tr> <tr> <td>---</td> <td><math>W &gt; 0.10</math></td> <td>As round type</td> </tr> <tr> <td>Total</td> <td></td> <td>5</td> </tr> </tbody> </table>	Dimension (diameter : $\Phi$ )	Acceptance (Q'ty)		A area	B area	$\Phi \ 0.25$	Ignore	Ignore	$0.25 < \Phi \ 0.50$	5	$\Phi > 0.50$	0	Total	5		Length (L)	Width (W)	Acceptance (Q'ty)		A area	B area	---	$W \ 0.03$	Ignore	Ignore	$L \ 10.0$	$0.03 < W \ 0.05$	4	$L \ 5.0$	$0.05 < W \ 0.10$	2	---	$W > 0.10$	As round type	Total		5	Minor
Dimension (diameter : $\Phi$ )	Acceptance (Q'ty)																																							
	A area	B area																																						
$\Phi \ 0.25$	Ignore	Ignore																																						
$0.25 < \Phi \ 0.50$	5																																							
$\Phi > 0.50$	0																																							
Total	5																																							
Length (L)	Width (W)	Acceptance (Q'ty)																																						
		A area	B area																																					
---	$W \ 0.03$	Ignore	Ignore																																					
$L \ 10.0$	$0.03 < W \ 0.05$	4																																						
$L \ 5.0$	$0.05 < W \ 0.10$	2																																						
---	$W > 0.10$	As round type																																						
Total		5																																						
07	<p><b>Polarizer Bubble</b></p>	<table border="1" data-bbox="494 1512 1340 1937"> <thead> <tr> <th rowspan="2">Dimension (diameter : <math>\Phi</math>)</th> <th colspan="2">Acceptance (Q'ty)</th> </tr> <tr> <th>A area</th> <th>B area</th> </tr> </thead> <tbody> <tr> <td><math>\Phi \ 0.25</math></td> <td>Ignore</td> <td rowspan="5">Ignore</td> </tr> <tr> <td><math>0.25 &lt; \Phi \ 0.50</math></td> <td>4</td> </tr> <tr> <td><math>0.50 &lt; \Phi \ 0.80</math></td> <td>1</td> </tr> <tr> <td><math>\Phi &gt; 0.80</math></td> <td>0</td> </tr> <tr> <td>Total</td> <td>5</td> </tr> </tbody> </table>	Dimension (diameter : $\Phi$ )	Acceptance (Q'ty)		A area	B area	$\Phi \ 0.25$	Ignore	Ignore	$0.25 < \Phi \ 0.50$	4	$0.50 < \Phi \ 0.80$	1	$\Phi > 0.80$	0	Total	5	Minor																					
Dimension (diameter : $\Phi$ )	Acceptance (Q'ty)																																							
	A area	B area																																						
$\Phi \ 0.25$	Ignore	Ignore																																						
$0.25 < \Phi \ 0.50$	4																																							
$0.50 < \Phi \ 0.80$	1																																							
$\Phi > 0.80$	0																																							
Total	5																																							

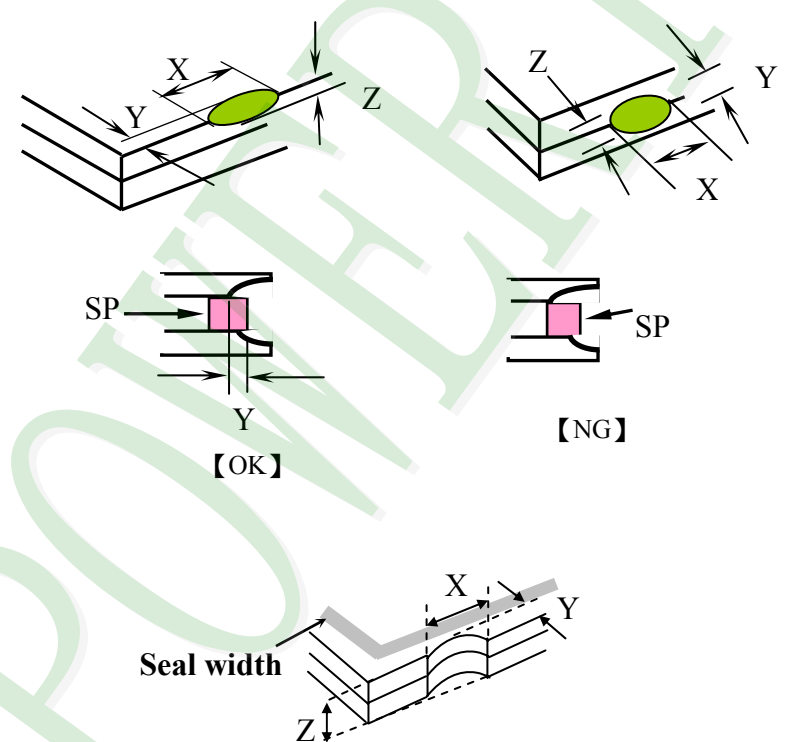
NO	Item	Criterion	Level						
08	The crack of glass	<p><b>Symbols :</b></p> <p><b>X :</b> The length of crack  <b>Z :</b> The thickness of crack  <b>t :</b> The thickness of glass</p> <p><b>Y :</b> The width of crack.  <b>W :</b> terminal length  <b>a :</b> LCD side length</p>	Minor						
		<p><b>8.1 General glass chip :</b></p> <p><b>8.1.1 Chip on panel surface and crack between panels:</b></p>  <table border="1" data-bbox="539 1590 1353 1881"> <thead> <tr> <th>X</th> <th>Y</th> <th>Z</th> </tr> </thead> <tbody> <tr> <td>a</td> <td>Crack can't enter viewing area</td> <td>1/2 t</td> </tr> <tr> <td>a</td> <td>Crack can't exceed the half of SP width.</td> <td>1/2 t &lt; Z    2 t</td> </tr> </tbody> </table>		X	Y	Z	a	Crack can't enter viewing area	1/2 t
X	Y	Z							
a	Crack can't enter viewing area	1/2 t							
a	Crack can't exceed the half of SP width.	1/2 t < Z    2 t							

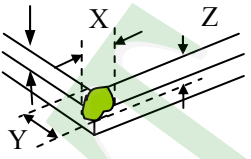
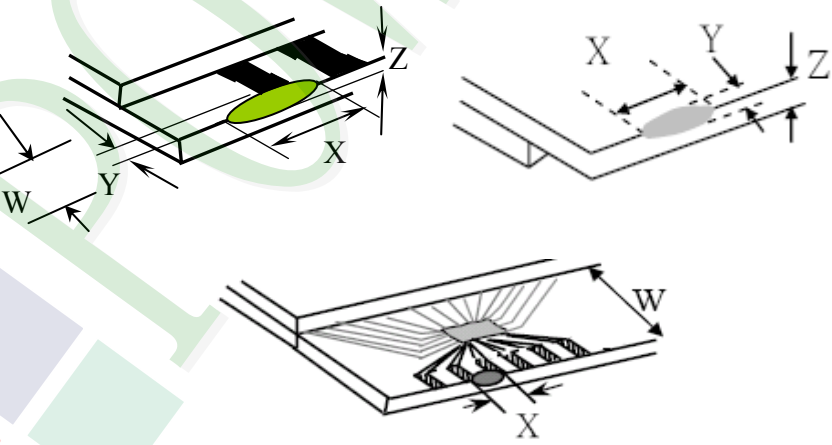
NO	Item	Criterion	Level												
08	The crack of glass	<p>Symbols :</p> <p>X : The length of crack                      Z : The thickness of crack                      t : The thickness of glass</p> <p>Y : The width of crack.                      W : terminal length                      a : LCD side length</p> <hr/> <p>8.1.2 Corner crack :</p>  <table border="1" data-bbox="520 779 1337 1070"> <thead> <tr> <th>X</th> <th>Y</th> <th>Z</th> </tr> </thead> <tbody> <tr> <td>1/5 a</td> <td>Crack can't enter viewing area</td> <td>Z 1/2 t</td> </tr> <tr> <td>1/5 a</td> <td>Crack can't exceed the half of SP width.</td> <td>1/2 t &lt; Z 2 t</td> </tr> </tbody> </table>	X	Y	Z	1/5 a	Crack can't enter viewing area	Z 1/2 t	1/5 a	Crack can't exceed the half of SP width.	1/2 t < Z 2 t				
		X	Y	Z											
1/5 a	Crack can't enter viewing area	Z 1/2 t													
1/5 a	Crack can't exceed the half of SP width.	1/2 t < Z 2 t													
		<p>8.2 Protrusion over terminal :</p> <p>8.2.1 Chip on electrode pad :</p>  <table border="1" data-bbox="560 1709 1347 1883"> <thead> <tr> <th></th> <th>X</th> <th>Y</th> <th>Z</th> </tr> </thead> <tbody> <tr> <td>Front</td> <td>a</td> <td>≤ 1/2 W</td> <td>≤ t</td> </tr> <tr> <td>Back</td> <td>a</td> <td>≤ W</td> <td>≤ 1/2 t</td> </tr> </tbody> </table>		X	Y	Z	Front	a	≤ 1/2 W	≤ t	Back	a	≤ W	≤ 1/2 t	Minor
	X	Y	Z												
Front	a	≤ 1/2 W	≤ t												
Back	a	≤ W	≤ 1/2 t												



◆Specification For TFT-LCD Module 3.5" ~10" :

(Ver.B01)

NO	Item	Criterion	Level
09	Backlight elements	9.1 Backlight can't work normally.	Major
		9.2 Backlight doesn't light or color is wrong.	Major
		9.3 Illumination source flickers when lit.	Major
10	General appearance	10.1 Pin type 、 quantity 、 dimension must match type in structure diagram.	Major
		10.2 No short circuits in components on PCB or FPC .	Major
		10.3 Parts on PCB or FPC must be the same as on the production characteristic chart .There should be no wrong parts , missing parts or excess parts.	Major
		10.4 Product packaging must the same as specified on packaging specification sheet.	Minor
		10.5 The folding and peeled off in polarizer are not acceptable.	Minor
		10.6 The PCB or FPC between B/L assembled distance(PCB or FPC ) is 1.5 mm.	Minor





## 5. PRECAUTION RELATING PRODUCT HANDLING

### 5.1 SAFETY

- 5.1.1 If the LCD panel breaks , be careful not to get the liquid crystal to touch your skin.
- 5.1.2 If the liquid crystal touches your skin or clothes , please wash it off immediately by using soap and water.

### 5.2 HANDLING

- 5.2.1 Avoid any strong mechanical shock which can break the glass.
- 5.2.2 Avoid static electricity which can damage the CMOS LSI—When working with the module , be sure to ground your body and any electrical equipment you may be using.
- 5.2.3 Do not remove the panel or frame from the module.
- 5.2.4 The polarizing plate of the display is very fragile. So , please handle it very carefully, do not touch , push or rub the exposed polarizing with anything harder than an HB pencil lead (glass , tweezers , etc.)
- 5.2.5 Do not wipe the polarizing plate with a dry cloth , as it may easily scratch the surface of plate.
- 5.2.6 Do not touch the display area with bare hands , this will stain the display area.
- 5.2.7 Do not use ketonics solvent & aromatic solvent. Use with a soft cloth soaked with a cleaning naphtha solvent.
- 5.2.8 To control temperature and time of soldering is  $320 \pm 10^{\circ}\text{C}$  and 3-5 sec.
- 5.2.9 To avoid liquid (include organic solvent) stained on LCM

### 5.3 STORAGE

- 5.3.1 Store the panel or module in a dark place where the temperature is  $25^{\circ}\text{C} \pm 5^{\circ}\text{C}$  and the humidity is below 65% RH.
- 5.3.2 Do not place the module near organics solvents or corrosive gases.
- 5.3.3 Do not crush , shake , or jolt the module.

### 5.4 TERMS OF WARRANTY

- 5.4.1 Applicable warrant period  
The period is within thirteen months since the date of shipping out under normal using and storage conditions.
- 5.4.2 Unaccepted responsibility  
This product has been manufactured to your company's specification as a part for use in your company's general electronic products. It is guaranteed to perform according to delivery specifications. For any other use apart from general electronic equipment, we cannot take responsibility if the product is used in nuclear power control equipment, aerospace equipment , fire and security systems or any other applications in which there is a direct risk to human life and where extremely high levels of reliability are required.





