

Version : 0.1

Preliminary

TECHNICAL SPECIFICATION
MODEL NO : PM070WX7

The content of this information is subject to be changed without notice.
Please contact PVI or its agent for further information.

Customer's Confirmation

Customer _____

Date _____

By _____

PVI's Confirmation

Dep	FAE	Panel Design	Electronic Design	Mechanical Design	Product Verification	Prepared by
SIGN	劉豐發	李合豐	金建強	申張傑	張玉	葉弘毅

TECHNICAL SPECIFICATION

CONTENTS

NO.	ITEM	PAGE
-	Cover	1
-	Contents	2
1	Application	3
2	Features	3
3	Mechanical Specifications	3
4	Mechanical Drawing of TFT-LCD module	4
5	Input / Output Terminals	6
6	Touch Panel Characteristics	10
7	Absolute Maximum Ratings	11
8	Electrical Characteristics	11
9	Pixel Arrangement	12
10	Display Color and Gray Scale Reference	13
11	Block Diagram	14
12	Interface Timing	15
13	Power On Sequence	20
14	Optical Characteristics	21
15	Handling Cautions	25
16	Reliability Test	26
17	Packing Diagram	27
	Revision History	28

1. Application

This data sheet applies to a color TFT LCD module, PM070WX7.

The application of panel are OA product, portable DVD, car TV(must use Analog to Digital driving board), which requires high quality flat panel display.

Prime View advises your systems use PVI's timing controller IC (PVI-2003A) which will generate proper timing signals to control it.

2. Features

- . Wide VGA (800*480 pixels) resolution
- . Module with resistive type touch panel .
- . Amorphous silicon TFT LCD panel with LED back-light unit
- . Pixel in stripe configuration
- . Thin and light weight
- . Display Colors : 262,144 colors
- . TTL transmission interface
- . Wide viewing angle

3. Mechanical Specifications

Parameter	Specifications	Unit
Screen Size	7.0 (diagonal)	inch
Display Format	800×(R, G, B)×480	dot
Display Colors	262,144	
Active Area	152.4(H)×91.44(V)	mm
Pixel Pitch	0.190(H)×0.190(V)	mm
Pixel Configuration	Stripe	
Outline Dimension	164.0(W)×103.0 (H)×7.45 (typ.) (D)	mm
Weight	TBD	g
LED Back-light	33-LED	
Surface treatment	Anti-glare and Wide View Film	
Display mode	Normally white	
Surface treatment of Touch Panel	3H	
Gray scale inversion direction	6 o'clock [ref to Page 22 viewing angle]	

Outline Drawing : Rear View (unit mm)

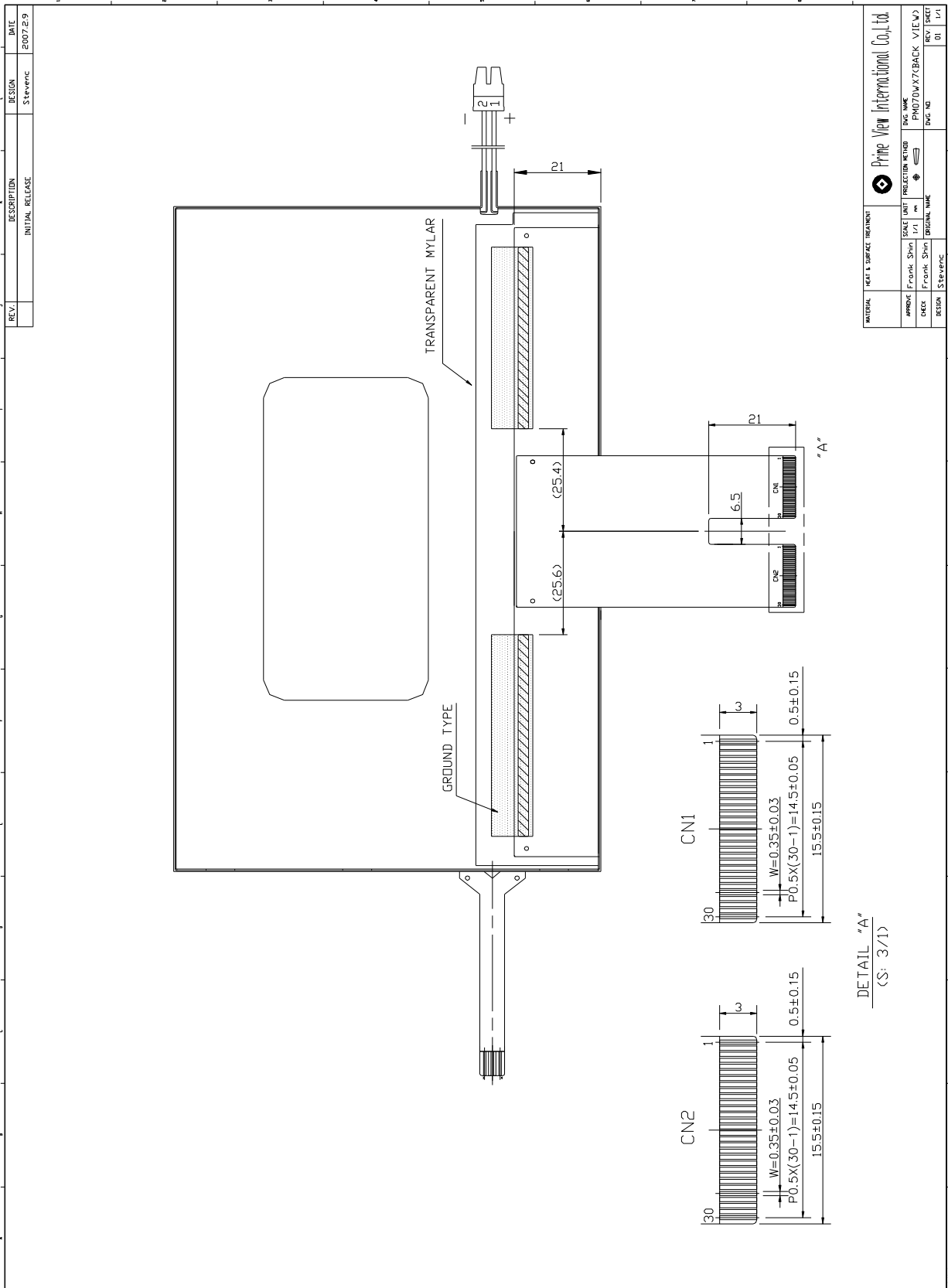

5. Input / Output Terminals
5-1) TFT-LCD Panel Driving
CN 1

LCD Module Connector
FPC Down Connect , 30 Pins , Pitch : 0.5 mm

Pin No.	Symbol	I/O	Function	Remark
1	DIO1	I/O	Horizontal Start Pulse Signal Input or Output	Note 5-1
2	VSS1	I	Ground	
3	VDD1	I	Power Supply	
4	CLK	I	Horizontal Shift Clock	
5	VSS1	I	Ground	
6	R/L	I	Right / Left selection	Note 5-1
7	R0	I	Red Data (LSB)	
8	R1	I	Red Data	
9	R2	I	Red Data	
10	R3	I	Red Data	
11	R4	I	Red Data	
12	R5	I	Red Data (MSB)	
13	VSS1	I	Ground	
14	G0	I	Green Data (LSB)	
15	G1	I	Green Data	
16	G2	I	Green Data	
17	G3	I	Green Data	
18	G4	I	Green Data	
19	G5	I	Green Data (MSB)	
20	VSS1	I	Ground	
21	B0	I	Blue Data (LSB)	
22	B1	I	Blue Data	
23	B2	I	Blue Data	
24	B3	I	Blue Data	
25	B4	I	Blue Data	
26	B5	I	Blue Data (MSB)	
27	LD	I	Load output signal	Note 5-2
28	REV	I	Data invert control	Note 5-3
29	POL	I	Polarity selection	Note 5-4
30	DIO2	I/O	Horizontal Start Pulse Signal Input or Output	Note 5-1

CN 2

Pin No.	Symbol	I/O	Function	Remark
1	VSS2	I	Ground	
2	V1	I	Gamma Voltage 1	Note 5-10
3	V2	I	Gamma Voltage 2	Note 5-10
4	V3	I	Gamma Voltage 3	Note 5-10
5	V4	I	Gamma Voltage 4	Note 5-10
6	V5	I	Gamma Voltage 5	Note 5-10
7	V6	I	Gamma Voltage 6	Note 5-10
8	V7	I	Gamma Voltage 7	Note 5-10
9	VSS2	I	Ground	
10	V8	I	Gamma Voltage 8	Note 5-10
11	V9	I	Gamma Voltage 9	Note 5-10
12	V10	I	Gamma Voltage 10	Note 5-10
13	V11	I	Gamma Voltage 11	Note 5-10
14	V12	I	Gamma Voltage 12	Note 5-10
15	V13	I	Gamma Voltage 13	Note 5-10
16	V14	I	Gamma Voltage 14	Note 5-10
17	VSS2	I	Ground	
18	VDD2	I	Voltage for analog circuit	Note 5-10
19	VCOM	I	Common Voltage	
20	XON	I	NC	
21	OE	I	Output Enable	Note 5-5
22	U/D	I	Up / Down Selection	Note 5-6
23	CKV	I	Vertical Shift Clock	Note 5-7
24	STVU	I/O	Vertical Shift Pulse Signal Input or Output	Note 5-6
25	STVD	I/O	Vertical Shift Pulse Signal Input or Output	Note 5-6
26	VGG	I	Gate On Voltage	Note 5-8
27	GND	I	Ground	
28	VCC	I	Voltage for logic circuit	
29	GND	I	Ground	
30	VEE	I	Gate Off Voltage	Note 5-9

Note 5-1: Select left or right shift

R/L	DIO1	DIO2	Shift
1	Input	Hi-Z	Left to right
0	Hi-Z	Input	Right to left

Note 5-2: Latch the polarity of outputs and switch the new data to outputs
At the rising edge (LD), latch the “POL” signal to control the polarity of the outputs.

Note 5-3: Control whether the Data R0~G5 are inverted or not. (PVI suggests connecting to GND)
When “REV=1”, these data will be inverted.
EX: “00”→”3F”, “07”→”38”, “15”→”2A”

Note 5-4: Polarity selector for dot-inversion control. Available at the rising edge of LD.
When POL=1: Even outputs range from V1~V7, and Odd outputs range from V8~V14;
When POL=0: Even outputs range from V8~V14, and Odd outputs range from V1~V7.

Note 5-5: When OE is connected to high “1”, the driver outputs are disabled (Gate output = V_{EE}).
Under this condition, the operation of registers will not be affected.

Note 5-6: Select up or down shift

U/D	STVU	STVD	Shift
1	Hi-Z	Input	Down to Up
0	Input	Hi-Z	Up to Down

Note 5-7: Gate driver shift clock

Note 5-8: Gate on voltage, $V_{GG}=+17V$.

Note 5-9: Gate off voltage, $V_{EE}=-8V$.

Note 5-10: Typical Application Circuit (When VDD2 = +9.5V)

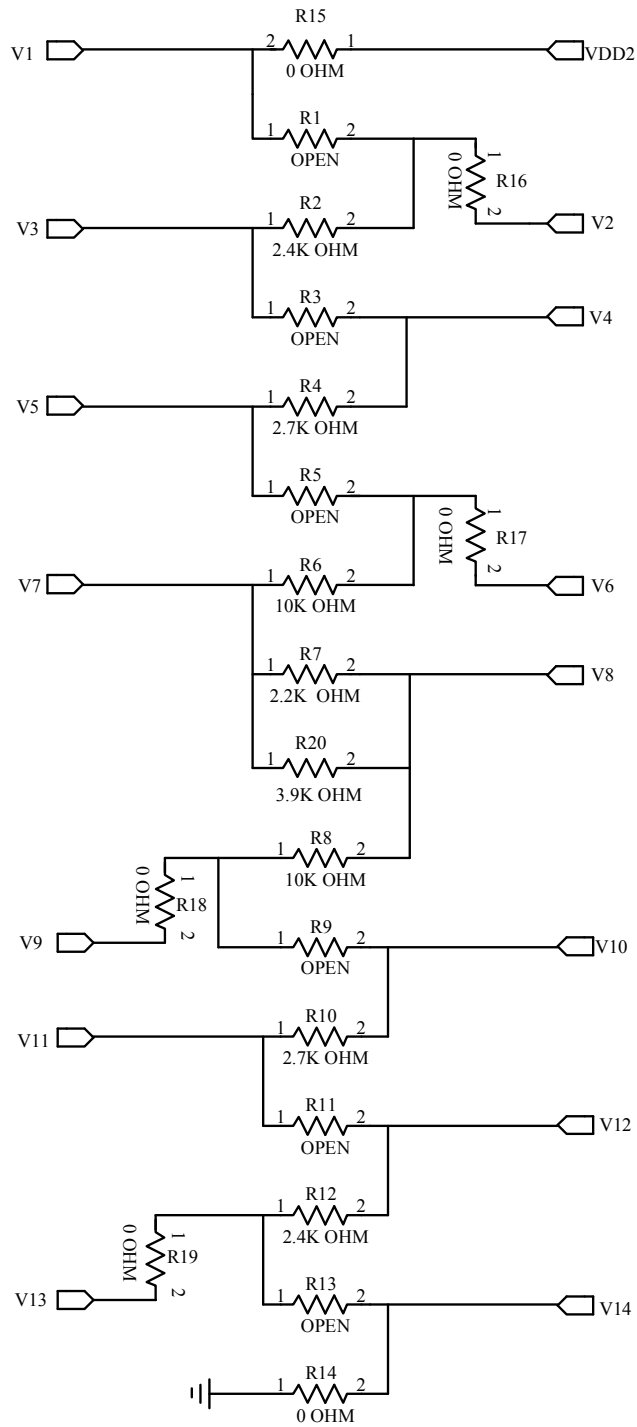

5-2) Backlight driving

Pin No	Symbol	Description	Remark
1	+	Input terminal (Positive electrode side)	Wire color : Red
2	-	Input terminal (Ground side)	Wire Color : Black

6.Touch Panel Characteristics
6.1) Pin assignment:

Pin	Symbol	Function	Remark
1	YU	Upper electrode Y(Upper side)	
2	XR	Lower electrode X(Right side)	
3	YD	Upper electrode Y(Down side)	
4	XL	Lower electrode X(Left side)	

6.2) Electrical Performance:

Parameters	Symbol	MIN.	Typ.	MAX.	Unit	Remark
Terminal Resistance	X	580	840	1200	Ω	
	Y	120	180	260	Ω	
Input Voltage	V _T	-	5.0	7.0	V	
Linearity(X ,Y direction)		-	-	± 1.5	%	
Insulation Impedance		20	-	-	M Ω	DC 25V
Response Time		-	-	15	ms	
Operation Force		-	-	50	g	Note 6-1

Note 6-1 Input through 0.8R stylus or finger.

6.3) Durability Performance
1. Hitting Durability:

At least 1,000,000 times with R8.0mm silicon rubber, 250g , 3times/sec .

2. Sliding Durability:

At least 100,000 times with R0.8mm polyacetal stylus , 250g , 60mm/sec.

7. Absolute Maximum Ratings:
 $V_{SS1}=V_{SS2}=GND=0V, T_a=25^{\circ}C$

Parameters	Symbol	MIN.	MAX.	Unit	Remark
Supply Voltage	V_{DD1}	-0.3	5.0	V	
	V_{CC}			V	
	V_{DD2}	-0.5	12.0	V	
	V_{GG}	-0.3	40.0	V	
	$V_{GG}-V_{EE}$	-0.3	40	V	
	V_{EE}	-20	0.3	V	
Digital Input	V_{IN}	-0.5	$V_{CC}+0.5$	V	

8. Electrical Characteristics

8-1) Recommended Operating Conditions:

 $V_{SS1}=V_{SS2}=GND=0V, T_a=25^{\circ}C$

Item	Symbol	Min.	Typ.	Max.	Unit	Remark
Supply Voltage for Source Driver	V_{DD1}	3.0	3.3	3.6	V	
	V_{DD2}	9	9.5	10	V	
Supply Voltage for Gate Driver	V_{GG}	-	17	-	V	
	V_{EE}	-	-8	-	V	
	V_{CC}	3.0	3.3	3.6	V	
Digital Input Voltage	V_{IH}	$0.8V_{DD1}$	-	V_{DD1}	V	
	V_{IL}	0	-	$0.2V_{DD1}$	V	
V_{com} Voltage	V_{com}	-	3.1	-	V	

8-2) Recommended Driving Condition for Back Light

 $GND = 0 V, T_a = 25^{\circ}C$

Parameter	Symbol	Min	TYP	MAX	Unit	Remark
Supply voltage of LED backlight	V_{LED}	-	11.0	11.5	V	$I_{LED} = 20 \text{ mA}$
Supply current of LED backlight	I_{LED}	-	20	-	mA	Note 8-1
Backlight Power Consumption	P_{LED}	-	2.42	2.53	W	Note 8-2

Note 8-1 : The LED driving condition is defined for each LED module. (3 LED Serial)

 Note 8-2 : $P_{LED} = V_{LED-1} * I_{LED-1} + V_{LED-2} * I_{LED-2} \dots + V_{LED-10} * I_{LED-10} + V_{LED-11} * I_{LED-11}$

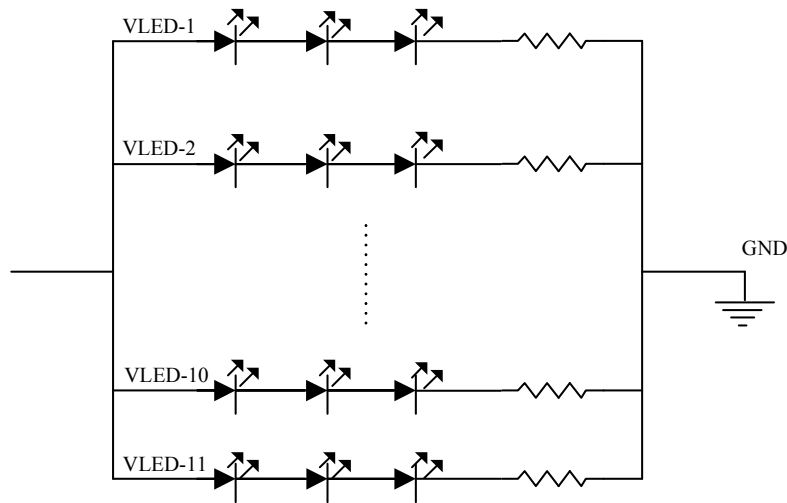

8-3) Power Consumption

Parameter	Symbol	Condition	Typ.	Max.	Unit	Remark
Supply Current for Gate Driver (Hi level)	I_{GG}	$V_{GG}=+17V$	0.32	0.41	mA	
Supply Current for Gate Driver (Low level)	I_{EE}	$V_{EE}=-8.0V$	3.35	4.19	mA	
Supply Current for Source Driver (Digital)	I_{DD1}	$V_{DD1}=+3.3V$	6.0	10.0	mA	
Supply Current for Source Driver (Analog)	I_{DD2}	$V_{DD2}=+9.5V$	20	27.5	mA	
Supply Current for Gate Driver (Digital)	I_{CC}	$V_{CC}=+3.3V$	0.01	0.013	mA	
LCD Panel Power Consumption(W/O B/L)	-	-	251.97	347.26	mW	Note 8-3
Total Power Consumption	-	-	2.68	-	W	

Note 8-3: Back light lamp power consumption is calculated by $I_L \times V_L$.

9. Pixel Arrangement

The LCD module pixel arrangement is the stripe.

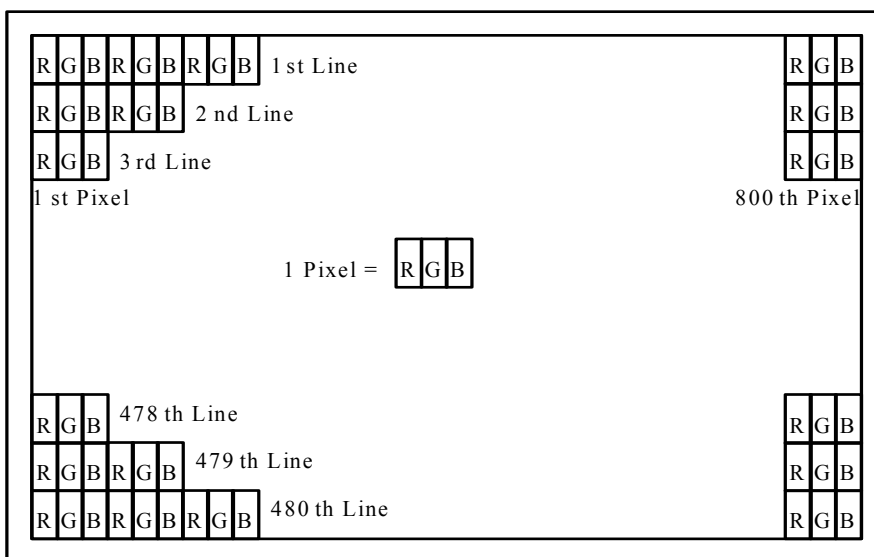

10. Display Color and Gray Scale Reference

Color		Input Color Data																	
		Red						Green						Blue					
		R5	R4	R3	R2	R1	R0	G5	G4	G3	G2	G1	G0	B5	B4	B3	B2	B1	B0
Basic Colors	Black	0	0	0	0	0	0	0	0	0	0	0	0	0	0	0	0	0	0
	Red (63)	1	1	1	1	1	1	0	0	0	0	0	0	0	0	0	0	0	0
	Green (63)	0	0	0	0	0	0	1	1	1	1	1	1	0	0	0	0	0	0
	Blue (63)	0	0	0	0	0	0	0	0	0	0	0	0	1	1	1	1	1	1
	Cyan	0	0	0	0	0	0	1	1	1	1	1	1	1	1	1	1	1	1
	Magenta	1	1	1	1	1	1	0	0	0	0	0	0	1	1	1	1	1	1
	Yellow	1	1	1	1	1	1	1	1	1	1	1	1	0	0	0	0	0	0
	White	1	1	1	1	1	1	1	1	1	1	1	1	1	1	1	1	1	1
Red	Red (00)	0	0	0	0	0	0	0	0	0	0	0	0	0	0	0	0	0	0
	Red (01)	0	0	0	0	0	1	0	0	0	0	0	0	0	0	0	0	0	0
	Red (02)	0	0	0	0	1	0	0	0	0	0	0	0	0	0	0	0	0	0
	Darker																		
	↓	↓	↓	↓	↓	↓	↓	↓	↓	↓	↓	↓	↓	↓	↓	↓	↓	↓	↓
	Brighter																		
	Red (61)	1	1	1	1	0	1	0	0	0	0	0	0	0	0	0	0	0	0
	Red (62)	1	1	1	1	1	0	0	0	0	0	0	0	0	0	0	0	0	0
	Red (63)	1	1	1	1	1	1	0	0	0	0	0	0	0	0	0	0	0	0
Green	Green (00)	0	0	0	0	0	0	0	0	0	0	0	0	0	0	0	0	0	0
	Green (01)	0	0	0	0	0	0	0	0	0	0	0	1	0	0	0	0	0	0
	Green (02)	0	0	0	0	0	0	0	0	0	0	1	0	0	0	0	0	0	0
	Darker																		
	↓	↓	↓	↓	↓	↓	↓	↓	↓	↓	↓	↓	↓	↓	↓	↓	↓	↓	↓
	Brighter																		
	Green (61)	0	0	0	0	0	0	1	1	1	1	0	1	0	0	0	0	0	0
	Green (62)	0	0	0	0	0	0	1	1	1	1	1	0	0	0	0	0	0	0
	Green (63)	0	0	0	0	0	0	1	1	1	1	1	1	0	0	0	0	0	0
Blue	Blue (00)	0	0	0	0	0	0	0	0	0	0	0	0	0	0	0	0	0	0
	Blue (01)	0	0	0	0	0	0	0	0	0	0	0	0	0	0	0	0	0	1
	Blue (02)	0	0	0	0	0	0	0	0	0	0	0	0	0	0	0	0	1	0
	Darker																		
	↓	↓	↓	↓	↓	↓	↓	↓	↓	↓	↓	↓	↓	↓	↓	↓	↓	↓	↓
	Brighter																		
	Blue (61)	0	0	0	0	0	0	0	0	0	0	0	0	1	1	1	1	0	1
	Blue (62)	0	0	0	0	0	0	0	0	0	0	0	0	1	1	1	1	1	0
	Blue (63)	0	0	0	0	0	0	0	0	0	0	0	0	1	1	1	1	1	1

11. Block Diagram

11-1) TFT-module Block Diagram

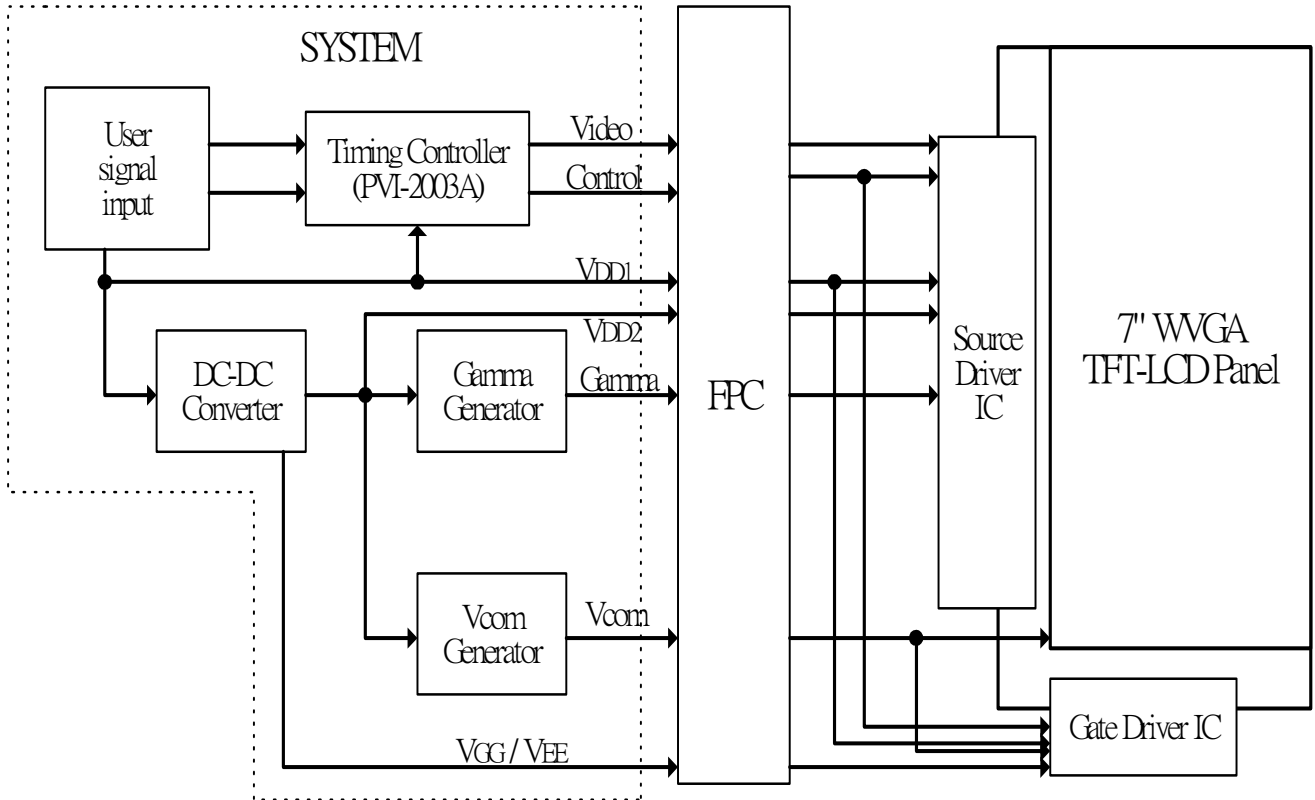

If you use PM070WX7, you must apply PVI-2003A (Timing controller) which will generate signal to support PM070WX7

12. Interface Timing

12.1) Timing Parameters

AC Electrical Characteristics ($V_{CC}=V_{DD1}=3.3V$, $V_{DD2}=9.5V$, $GND=V_{SS1}=V_{SS2}=0V$, $T_a=25^{\circ}C$)

Parameter	Symbol	Min.	Typ.	Max.	Unit
CLK Frequency	Fclk	-	32	40	MHz
CLK Pulse Width	Tew	25	-	-	ns
Data Set-up Time	Tsu	4	-	-	ns
Data Hold Time	Thd	2	-	-	ns
Propagation Delay of DIO2/1	Tphl	6	10	15	ns
Time That The Last Data to LD	Tld	1	-	-	T _{CPH}
Pulse width of LD	Twld	2	-	-	T _{CPH}
Time That LD to DIO1/2	Tlds	5	-	-	T _{CPH}
POL Set-up Time	Tpsu	6	-	-	ns
POL Hold Time	Tphd	6	-	-	ns
OE Pulse Width	T _{OEV}	1	-	-	μs
CKV Pulse Width	T _{CKV}	500	-	-	ns
STV Set-up Time	T _{SUV}	400	-	-	ns
STV Hold Time	T _{HDV}	400	-	-	ns
Horizontal Display Period	T _{HDP}	-	800	-	T _{CPH}
Horizontal Period Timing Range	T _{HP}	-	1056	-	T _{CPH}
Horizontal Lines Per Field	T _V	484	508	620	T _{HP}
Vertical Display Timing Range	T _{DV}	-	480	-	T _{HP}

12.2) Timing Diagram

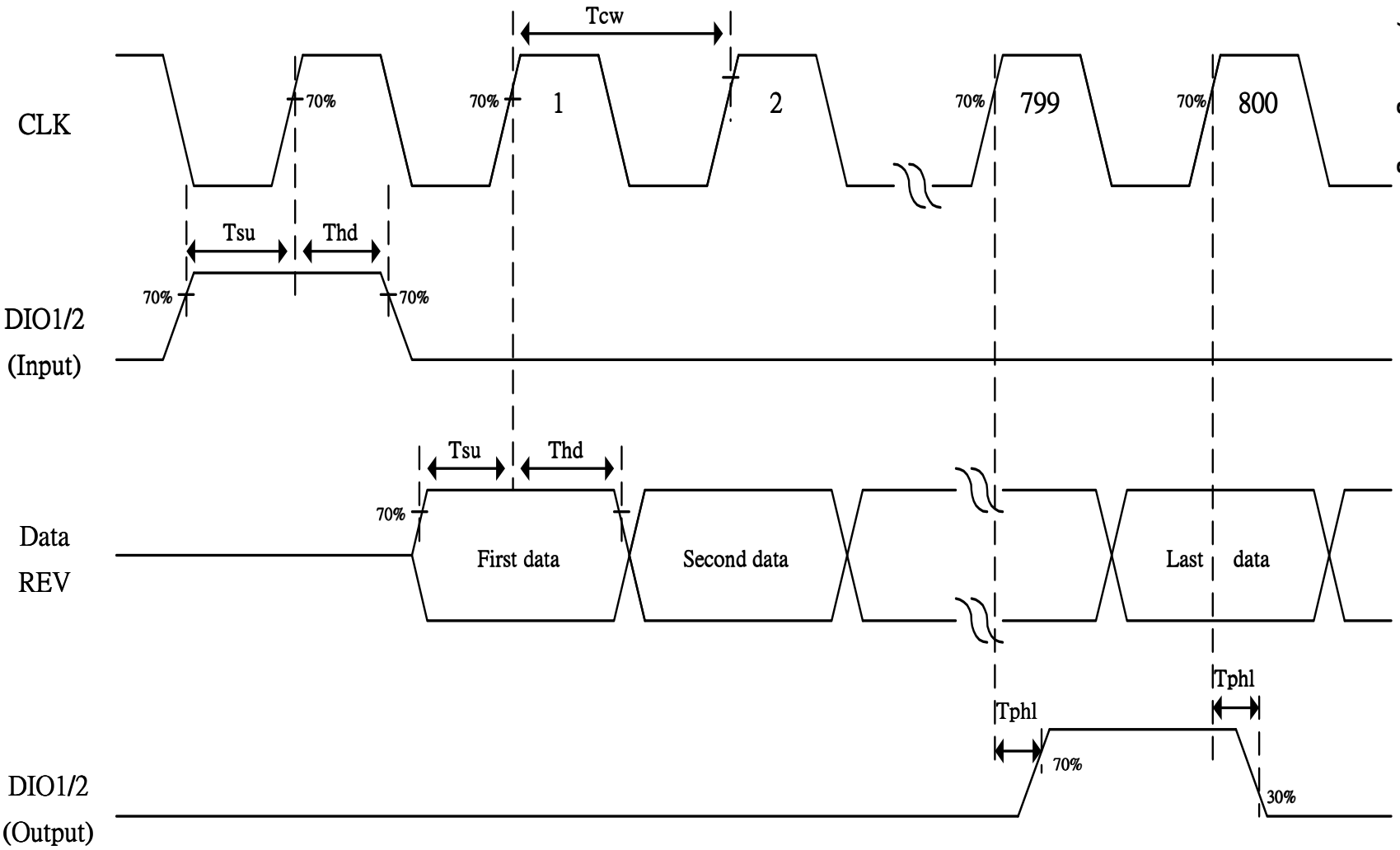

Fig. 11-1 Horizontal timing (1)

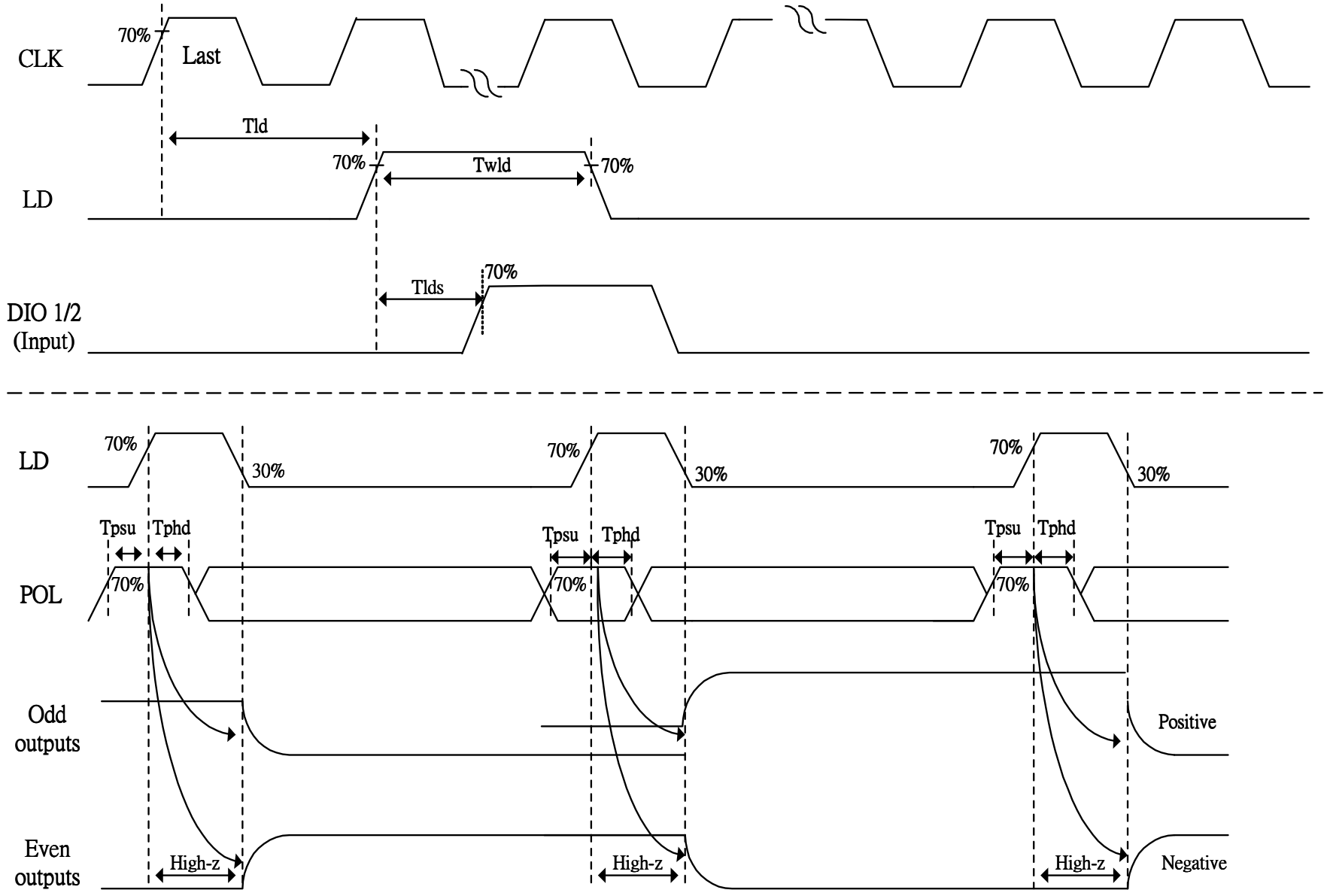

Fig. 11-2 Horizontal timing(2)

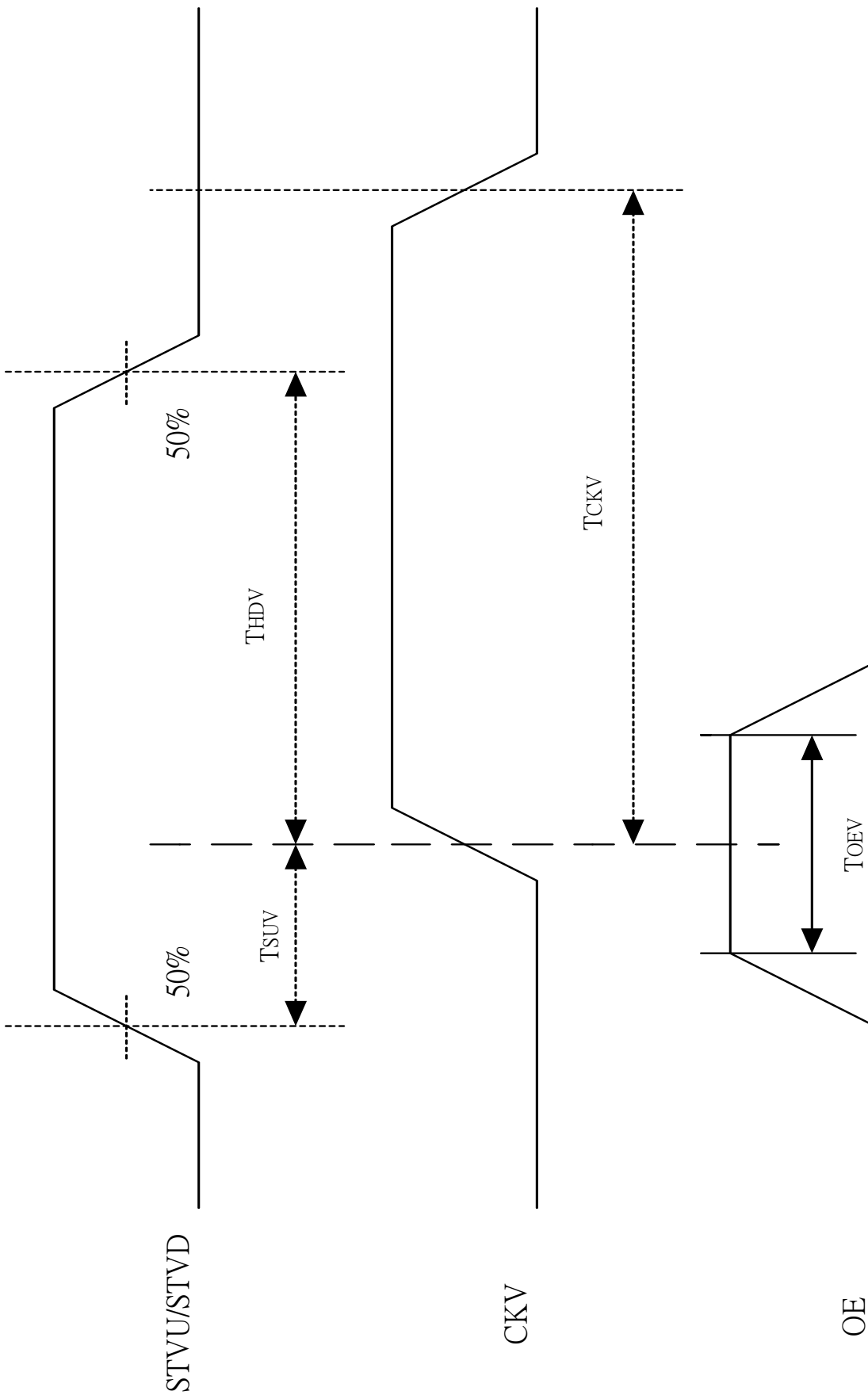

Fig. 11-3 Vertical shift clock timing

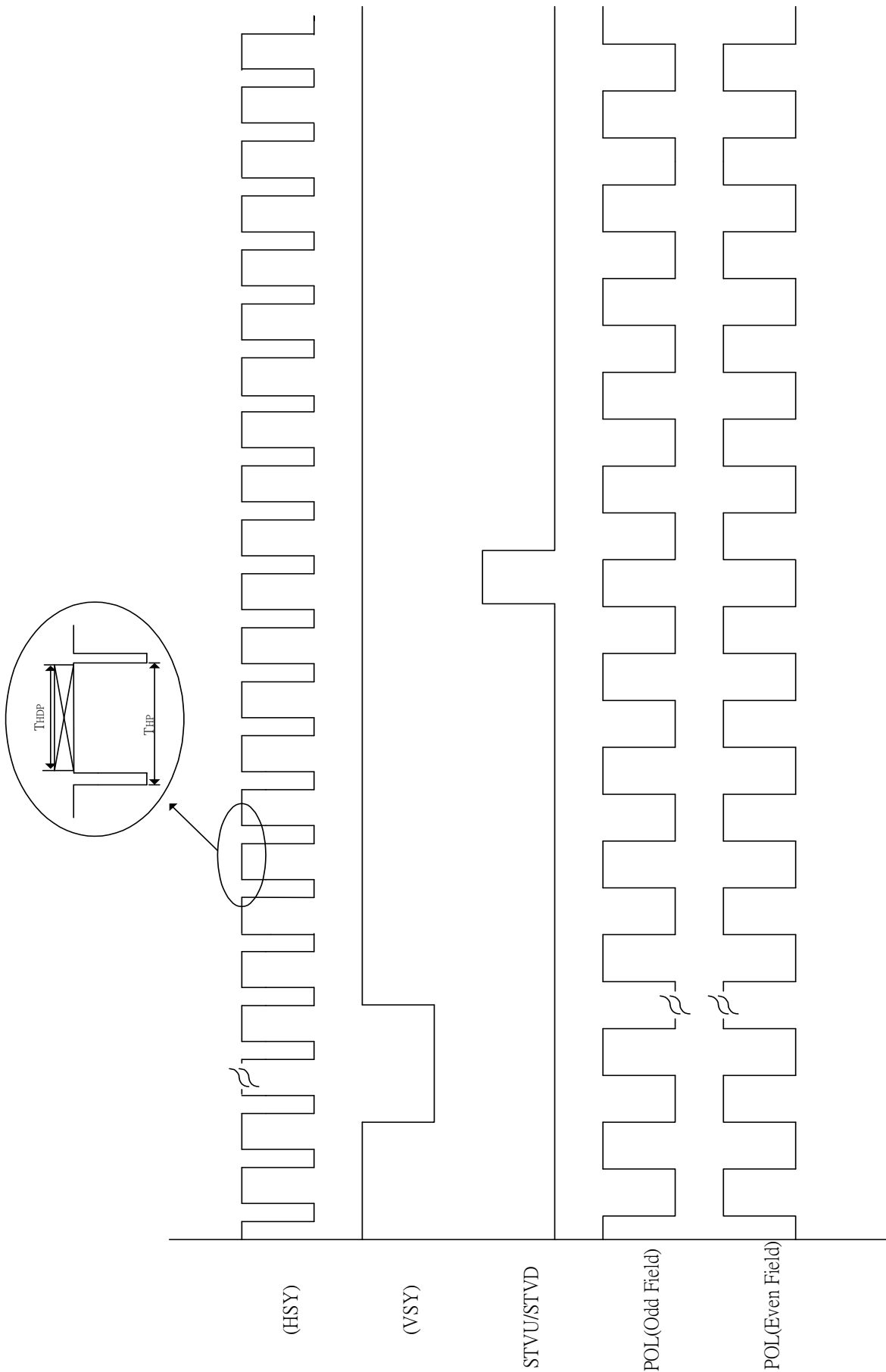
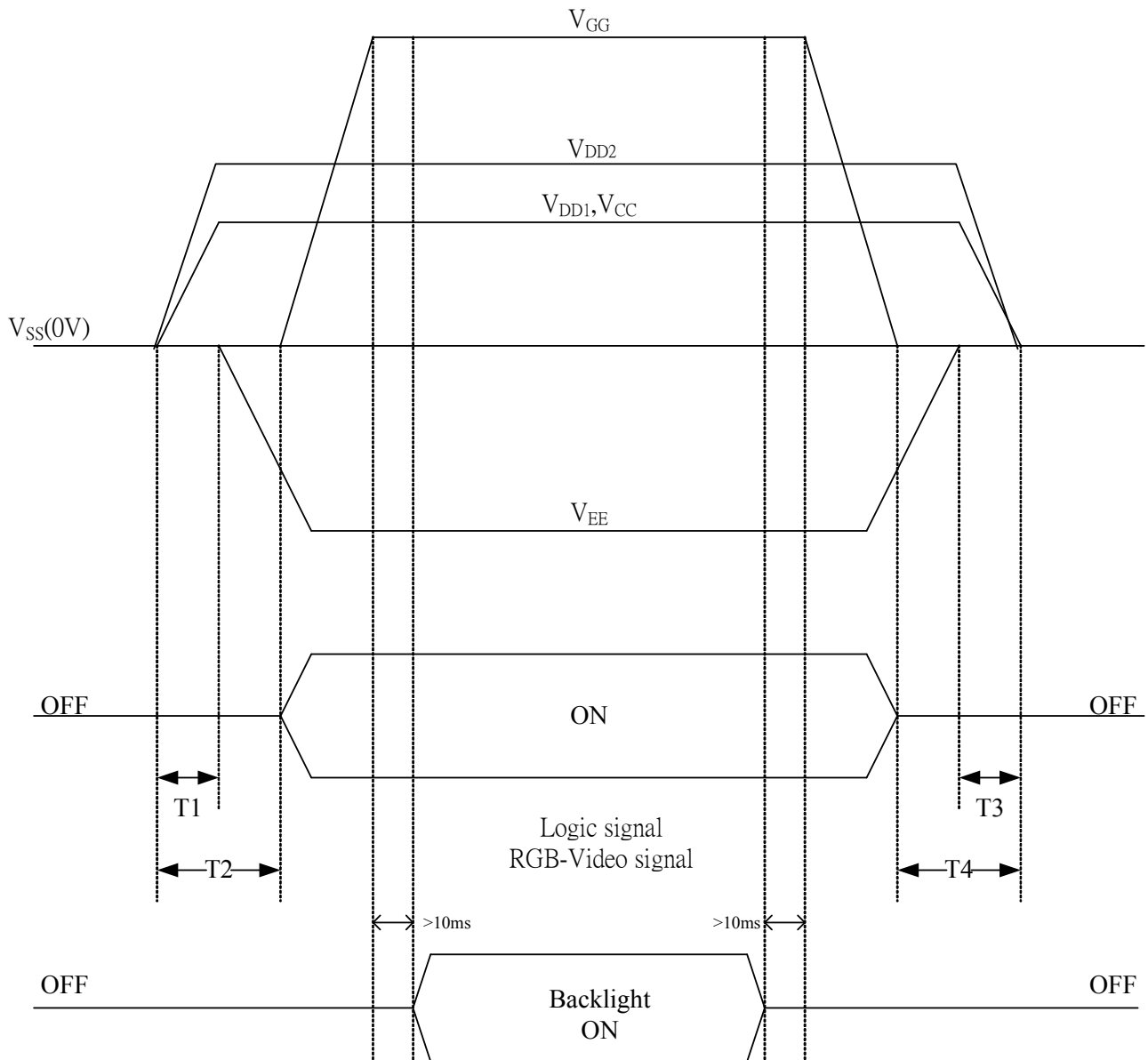

Fig. 11-4 Vertical timing

13. Power On Sequence



1. $1.10\text{ms} \leq T1 < T2$

2. $0\text{ms} < T3 \leq T4 \leq 10\text{ms}$

14. Optical Characteristics

14-1) Specification:

Ta=25°C

Parameter		Symbol	Condition	MIN.	TYP.	MAX.	Unit	Remarks
Viewing Angle	Horizontal	θ 21.22	CR \geq 10	\pm 55	\pm 60	-	deg	Note 14-1
	Vertical	θ (to 12 o'clock)		35	40	-	deg	
		θ (to 6 o'clock)		50	55	-	deg	
Contrast Ratio		CR	$\theta = 0^\circ$	250	400	-	-	Note 14-2
Response time	Rise	Tr	$\theta = 0^\circ$	-	15	30	ms	Note 14-3
	Fall	Tf		-	25	50	ms	
Brightness		L	$\theta = 0^\circ / \varphi = 0$	300	330		cd/m ²	
Luminance Uniformity		U		70	75	-	%	Note 14-4
LED Life Time		-	-	20000	30000	-	hr	Note 14-6
White Chromaticity		x	$\theta = 0^\circ / \varphi = 0$	0.27	0.30	0.33	-	
		y		0.30	0.33	0.36	-	
Cross Talk		-	$\theta = 0^\circ$	-	-	3.5	%	Note 14-5

All the optical measurement shall be executed 30 minutes after backlight being turn-on. The optical characteristics shall be measured in dark room (ambient illumination on panel surface less than 1 Lux). The measuring configuration shows as following figure.

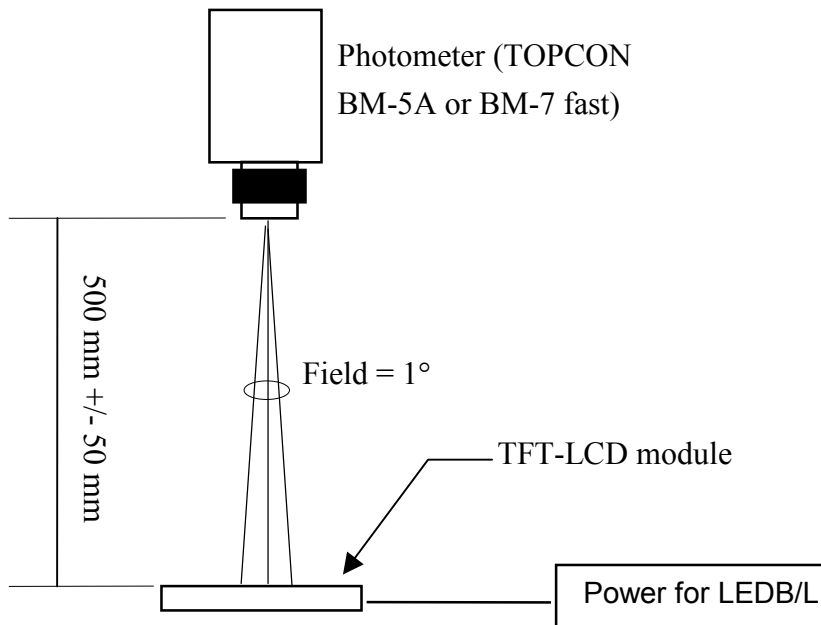

Optical characteristics measuring configuration

Topcon BM-5A or BM-7 fast luminance meter 1° field of view is used in the testing (after 30 minutes' operation). The typical luminance value is measured at LED current 20 mA.

Note 14-1: The definitions of viewing angles are as follow.

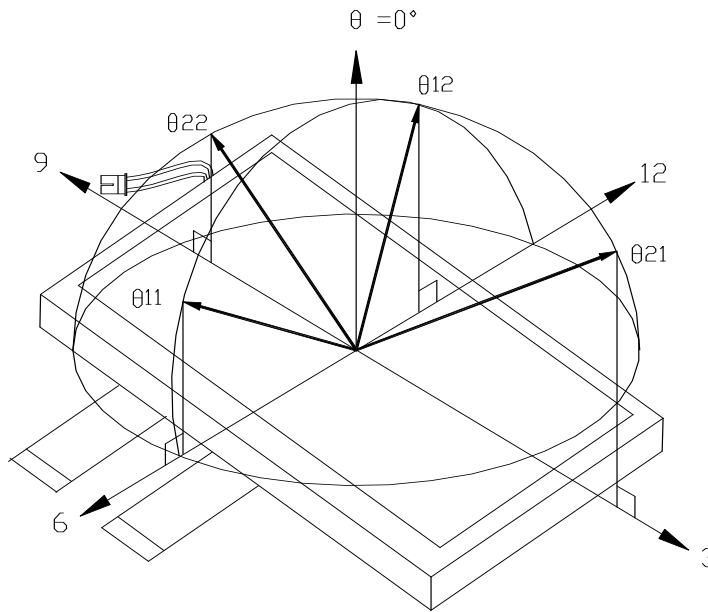

Note 14-2: The definition of contrast ratio $CR = \frac{\text{Luminance at gray level 63}}{\text{Luminance at gray level 0}}$

Note 14-3: Definition of Response Time T_r and T_f :

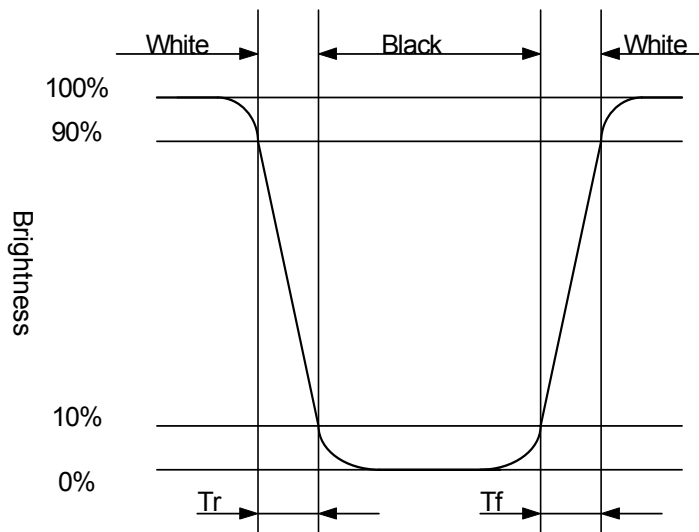

Note 14-4: The uniformity of LCD is defined as

$$U = \frac{\text{The Minimum Brightness of the 9 testing Points}}{\text{The Maximum Brightness of the 9 testing Points}}$$

Luminance meter : BM-5A or BM-7 fast(TOPCON)

Measurement distance : 500 mm +/- 50 mm

Ambient illumination : < 1 Lux

Measuring direction : Perpendicular to the surface of module

The test pattern is white (Gray Level 63).

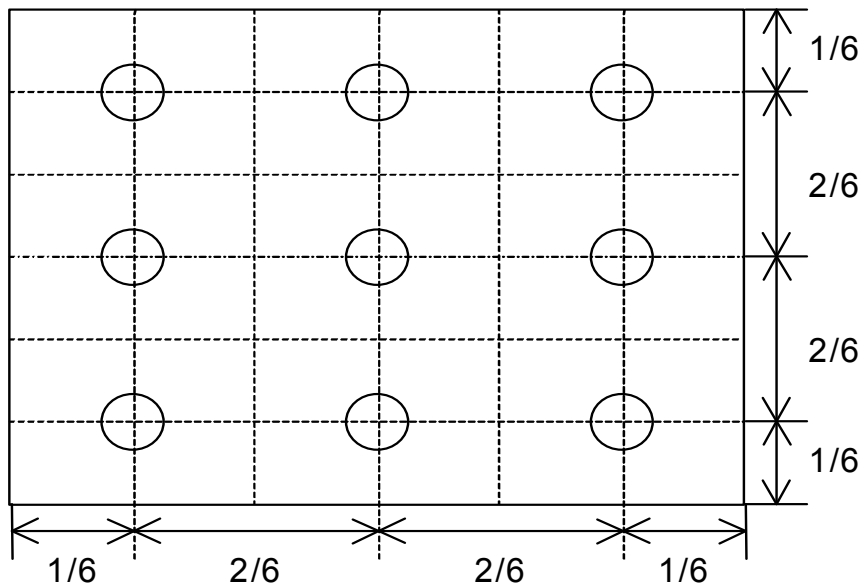

Note 14-5: Cross Talk (CTK) = $\frac{|YA-YB|}{YA} \times 100\%$

YA: Brightness of Pattern A

YB: Brightness of Pattern B

Luminance meter : BM 5A or BM-7 fast (TOPCON)

Measurement distance : 500 mm +/- 50 mm

Ambient illumination : < 1 Lux

Measuring direction : Perpendicular to the surface of module

Pattern A
(Gray Level 31)

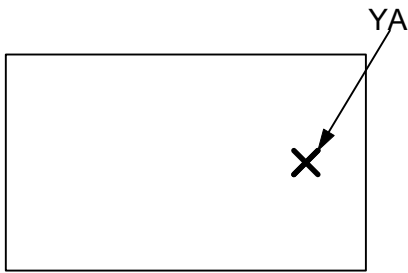

Pattern B
(Gray Level 31, central black box exclusive)

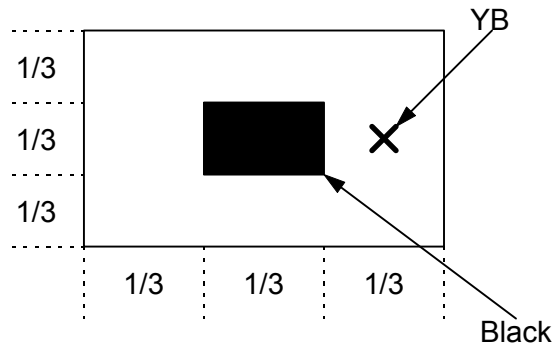

X: Measuring Point (A and B are at the same point.)

Black
(Gray Level 0)

Note 14-6: The "LED Life time " is defined as the module brightness decrease to 50% original Brightness that the ambient temperature is 25°C and $I_{LED} = 20mA$.

15. Handling Cautions

15-1) Mounting of module

- a) Please power off the module when you connect the input/output connector.
- b) Please connect the ground pattern of the inverter circuit surely. If the connection is not perfect, some following problems may happen possibly.
 - 1. The noise from the backlight unit will increase.
 - 2. The output from inverter circuit will be unstable.
 - 3. In some cases a part of module will heat.
- c) Polarizer which is made of soft material and susceptible to flaw must be handled carefully.
- d) Protective film (Laminator) is applied on surface to protect it against scratches and dirt. It is recommended to peel off the laminator before use and taking care of static electricity.

15-2) Precautions in mounting

- a) When metal part of the TFT-LCD module (shielding lid and rear case) is soiled, wipe it with soft dry cloth.
- b) Wipe off water drops or finger grease immediately. Long contact with water may cause discoloration or spots.
- c) TFT-LCD module uses glass which breaks or cracks easily if dropped or bumped on hard surface. Please handle with care.
- d) Since CMOS LSI is used in the module. So take care of static electricity and earth yourself when handling.

15-3) Adjusting module

- a) Adjusting volumes on the rear face of the module have been set optimally before shipment.
- b) Therefore, do not change any adjusted values. If adjusted values are changed, the specifications described may not be satisfied.

15-4) Others

- a) Do not expose the module to direct sunlight or intensive ultraviolet rays for many hours.
- b) Store the module at a room temperature place.
- c) The voltage of beginning electric discharge may over the normal voltage because of leakage current from approach conductor by to draw lump read lead line around.
- d) If LCD panel breaks, it is possibly that the liquid crystal escapes from the panel. Avoid putting it into eyes or mouth. When liquid crystal sticks on hands, clothes or feet. Wash it out immediately with soap.
- e) Observe all other precautionary requirements in handling general electronic components.
- f) Please adjust the voltage of common electrode as material of attachment by 1 module.

16. Reliability Test

No	Test Item	Test Condition	Remark
1	High Temperature Storage Test	Ta = +80°C, 240 hrs	
2	Low Temperature Storage Test	Ta = -30°C, 240 hrs	
3	High Temperature Operation Test	Ta = +70°C, 240 hrs	
4	Low Temperature Operation Test	Ta = -20°C, 240 hrs	
5	High Temperature & High Humidity Operation Test	Ta = +60°C, 90%RH, 240 hrs (No Condensation)	
6	Thermal Cycling Test (non-operating)	-30°C → +80°C, 100 Cycles 30min 30min	
7	Vibration Test (non-operating)	Frequency : 10 ~ 55 Hz, Amplitude : 1 mm Sweep time: 11 min Test Period: 6 Cycles for each direction of X, Y, Z	
8	Shock Test (non-operating)	100G, 6ms Direction: ±X, ±Y, ±Z Cycle: 3 times	
9	Electrostatic Discharge Test (non-operating)	200pF, 0Ω ±200V 1 time / each terminal	
10	Hitting Durability Test (Touch panel)	1,000,000 times, with R 8.0 mm silicon rubber, 250g, 3times/sec	
11	Sliding Durability Test (Touch panel)	100,000 times, with R 0.8 mm polyacetal stylus, 250g, 60mm/sec	

Ta: ambient temperature

Note: The protective film must be removed before temperature test.

[Criteria]

In the standard conditions, there is not display function NG issue occurred. (including : line defect ,no image), All the cosmetic specification is judged before the reliability stress.

17. Packing Diagram

ZONE	REV.	DOCUMENT NO.	DESCRIPTION	DATE	REV.BY
<p>NOTE:</p> <p>1.Q'TY: 40 pcs panel/carton. 2.Dimension: 530*295*230mm 3.Weight: 12 Kg</p>					
4		50-0100111	CARTON	1	
3		50-0500181	PINK Bag 115*230mm	40	抗靜電
2			PM070WX7	40	
1		50-0300862	瓦楞隔板緩衝材	1	上蓋+底座
ITEM	PART NO.	DESCRIPTION		QTY	REMARK
MTL.SPEC.		UNSPECIFIED TOL'S		REMARK	
		ANGLE			
		ROUGHNESS			
APPROVE	Frank Shin	07.02.10	SCALE	UNIT	SHEET
CHECK	Frank Shin	07.02.10			1 of 1
DRAWN	Stevenc	07.02.10	MTL.NO.		DWG FILE:
				REV. 01	A4 SIZE

元太科技工業股份有限公司
 Prime View International Co., Ltd.

Revision History

Rev.	Issued Date	Revised Contents
0.1	Feb. 09 , 2007	Preliminary