

Preliminary

**TECHNICAL SPECIFICATION**  
**MODEL NO : PD150XL1**

Customer's Confirmation

Customer \_\_\_\_\_

Date \_\_\_\_\_

By \_\_\_\_\_

PVI's Confirmation

Dep	FAE	Panel Design	Electronic Design	Mechanical Design	Product Verification	Prepared by
SIGN					張 天 欣	蔡 弘 毅

# ***TECHNICAL SPECIFICATION***

## **CONTENTS**

<b><i>NO.</i></b>	<b><i>ITEM</i></b>	<b><i>PAGE</i></b>
-	Cover	1
-	Contents	1
1	Application	3
2	Features	3
3	Mechanical Specifications	3
4	Mechanical Drawing of TFT-LCD Module	4
5	Input / Output Terminals	6
6	Absolute Maximum Ratings	7
7	Electrical Characteristics	7
8	Pixel Arrangement	10
9	Display Color and Gray Scale Reference	11
10	Block Diagram	12
11	Interface Timing	13
12	Power On Sequence	15
13	Optical Characteristics	16
14	Handling Cautions	18
15	Reliability Test	19
16	Packing Diagram	20
-	Revision History	-

## 1. Application

PD150XL1 is a 15.0" TFT Liquid Crystal Display module with 2 CCFL Backlight units and 20 pins LVDS interface. This module supports 1024 x 768 XGA mode and can display 16.2M colors.

The PSWG is to establish a set of displays with standard mechanical dimensions and select electrical interface requirements for an industry standard 15.0" XGA LCD panel and the inverter module for Backlights not built in.

This module can apply TFT-LCD monitor, TV, Factory application, Amusement Vehicle,... and so on.

## 2. Features

- XGA (1024 x 768 pixels) resolution
- DE(Data Enable) only mode
- LVDS Interface with 1pixel/clock
- PSWG (Panel Standardization Working Group)
- Wide operating temperature.

## 3. Mechanical Specifications

Parameter	Specifications	Unit
Screen Size	15.0 (diagonal)	inch
Display Format	1024×(R, G, B)×768	dot
Display Colors	16,194,227	
Active Area	304.128(H)×228.096(V)	mm
Pixel Pitch	0.297(H)×0.297(V)	mm
Pixel Configuration	Stripe	
Outline Dimension	326.5(W)×253.5(H)×14.0(typ.) (D)	mm
Weight	1080±100	g
Back-light	CCFL, 2 tube	
Surface treatment	Anti-Glare & Hard Coating	
Display mode	Normally Black	

4. Mechanical Drawing of TFT-LCD Module:

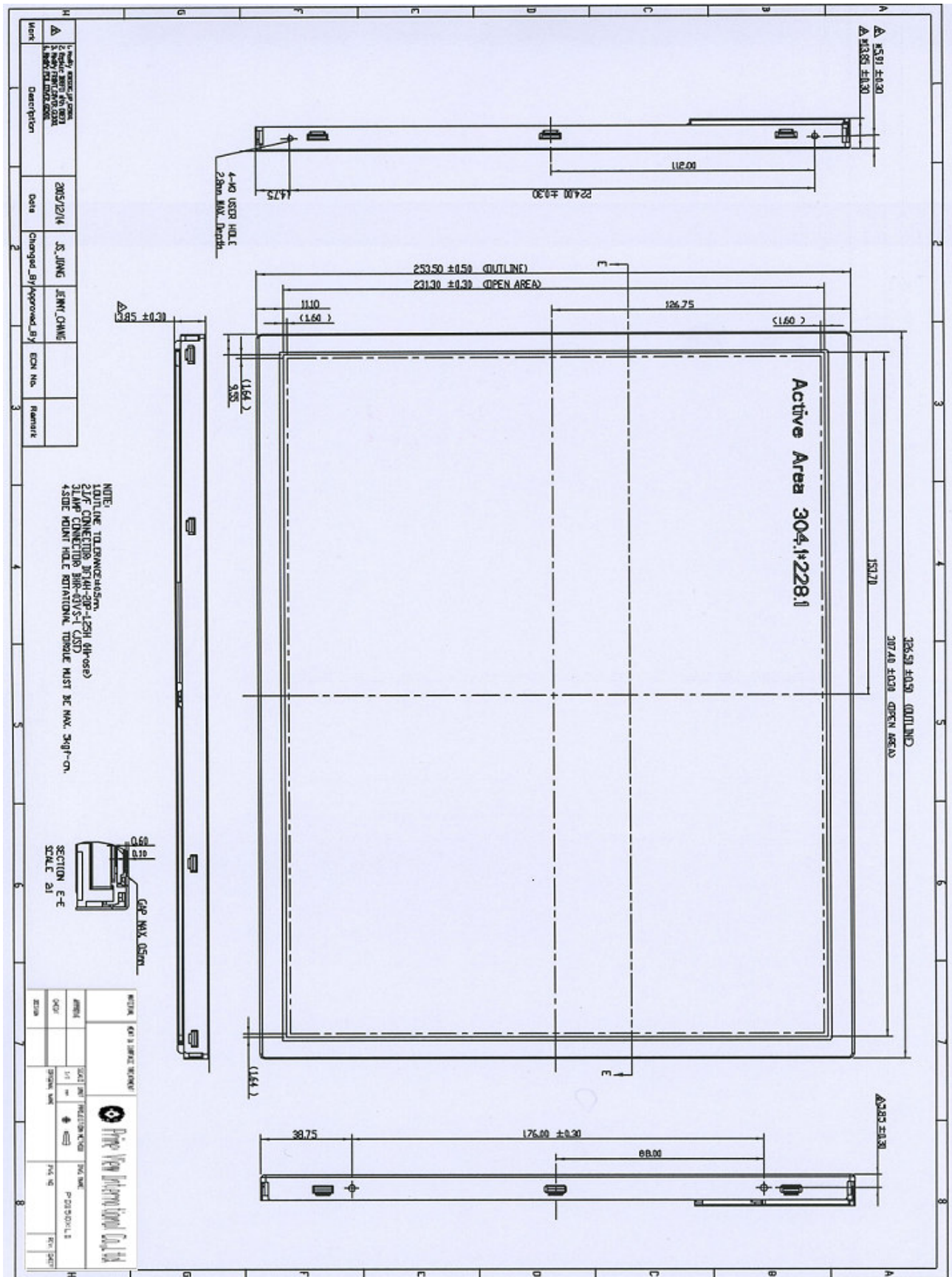

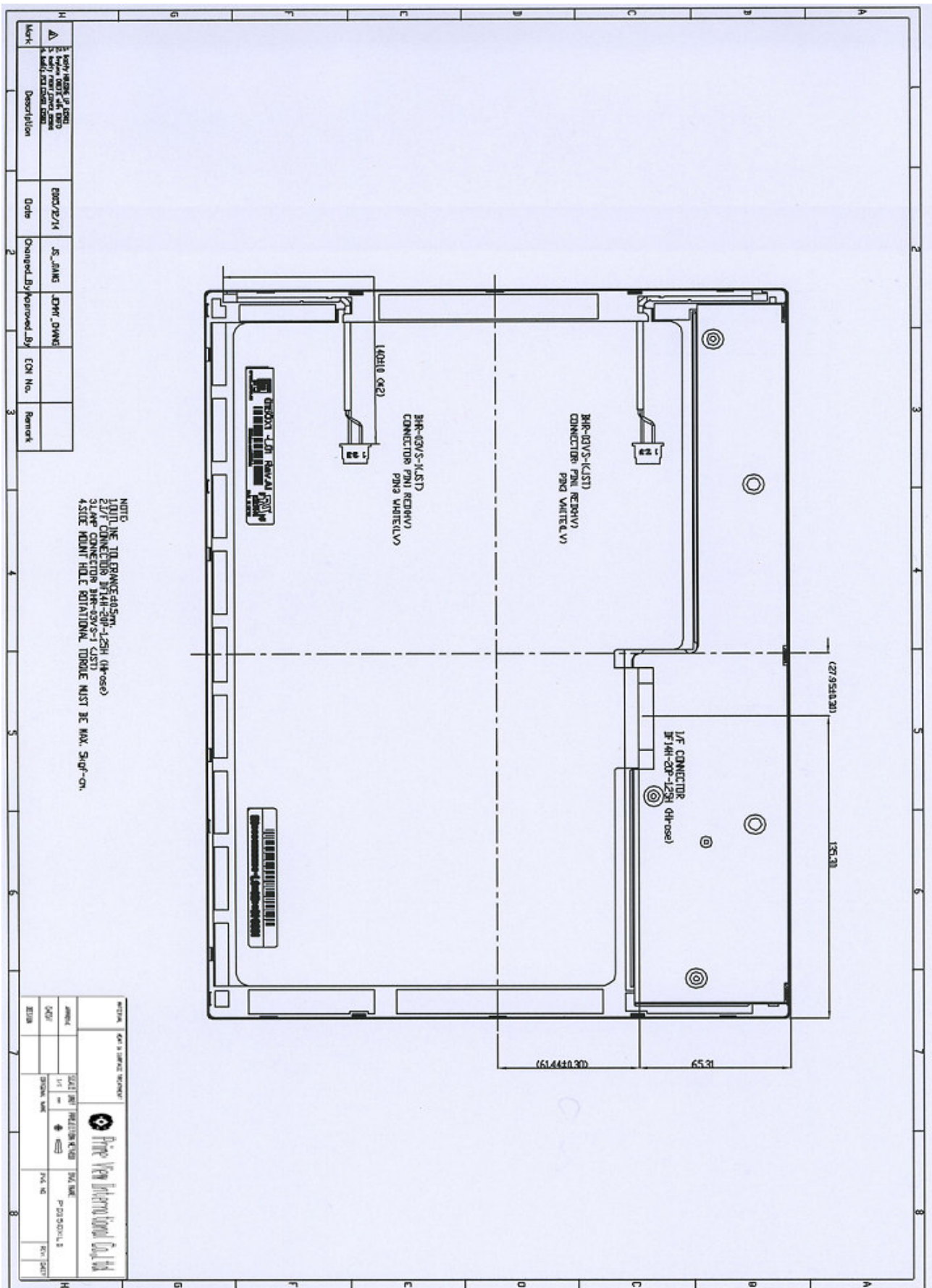

## 5. Input / Output Terminals

### 5-1) TFT-LCD Panel Driving

Connector type: [Hirose] DF14H-20P-1.25H

Pin No.	Symbol	Function	Remark
1	VDD	Power Supply (Typical)	+3.3V
2	VDD	Power Supply (Typical)	+3.3V
3	GND	Ground	
4	GND	Ground	
5	RXO-	LVDS Differential Data Input	Negative
6	RXO+	LVDS Differential Data Input	Positive
7	GND	Ground	
8	RX1-	LVDS Differential Data Input	Negative
9	RX1+	LVDS Differential Data Input	Positive
10	GND	Ground	
11	RX2-	LVDS Differential Data Input	Negative
12	RX2+	LVDS Differential Data Input	Positive
13	GND	Ground	
14	RXCLK-	LVDS Differential Data Input	Negative
15	RXCLK+	LVDS Differential Data Input	Positive
16	GND	Ground	
17	RX3-	Non-connection	Negative
18	RX3+	Non-connection	Positive
19	GND	Ground	
20	NC	Tied to ground	

### 5-2) Backlight driving

Connector Part No.: JST BHR-03VS-1 or equivalent

Pin No	Symbol	Description	Remark
1	HV	Input terminal (Hi voltage side)	Wire color : Pink
2	NA	NA	
3	LV	Input terminal (Low voltage side)	Wire Color : White ,Note 5-1

Note 5-1 : Low voltage side of backlight inverter connects with ground of inverter circuits.

### 6. Absolute Maximum Ratings:

The followings are maximum values, which if exceeded, may cause faulty operation or damage to the unit.

GND=0V, Ta=25°C

Parameters	Symbol	MIN.	MAX.	Unit	Remark
Supply Voltage	V <sub>CC</sub>	-0.3	+4.0	V	

### 7. Electrical Characteristics

7-1) Recommended Operating Conditions:

GND=0V, Ta=25°C

Parameter	Symbol	Value			Unit	Note	
		Min.	Typ.	Max.			
Power Supply Voltage	V <sub>DD</sub>	3.0	3.3	3.6	V	-	
Ripple Voltage	V <sub>RP</sub>	-	-	100	mVp-p	-	
Rush Current	I <sub>RUSH</sub>	-	-	2.0	A	Note 7-1	
Power Supply Current	White	I <sub>CC</sub>	-	500	-	mA	Note 7-2
	Black		-	750	-	mA	Note 7-3
Differential Input Voltage for LVDS receiver Threshold	“H” level	V <sub>IH</sub>	-	-	+100	mV	
	“L” level	V <sub>IL</sub>	-100	-	-	mV	
Terminating Resistor	R <sub>T</sub>	-	100	-	Ohm		

Note 7-1 The module should be always operated within above ranges.

Note 7-2 Measurement Conditions:

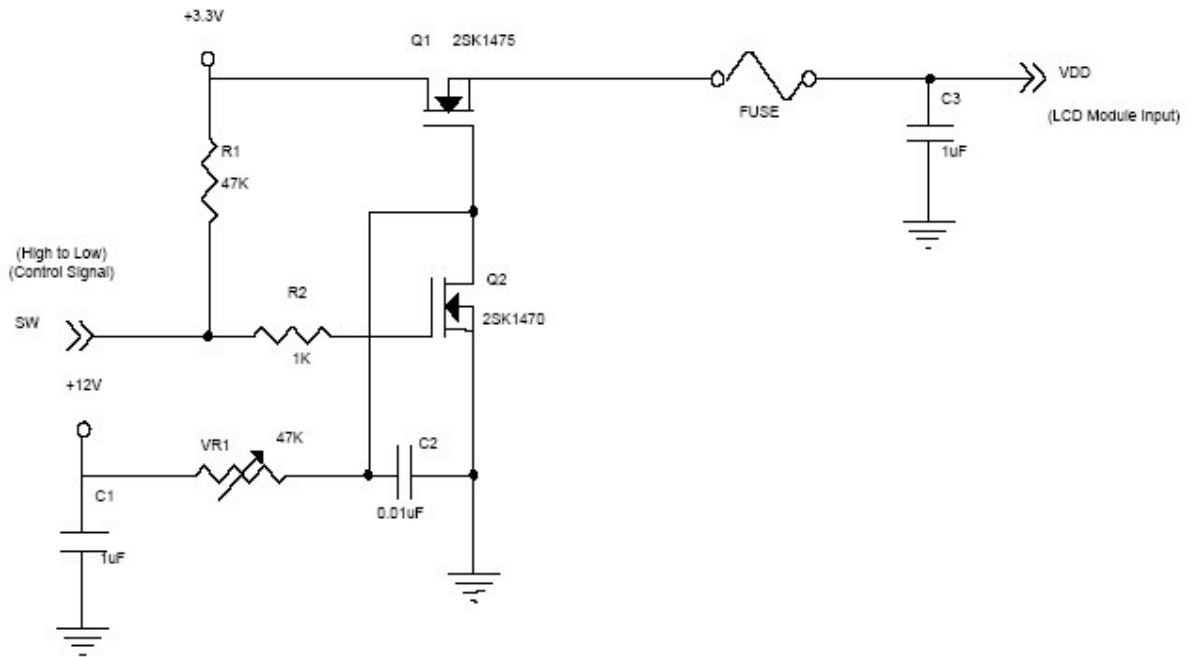

**Vcc rising time is 470μs**

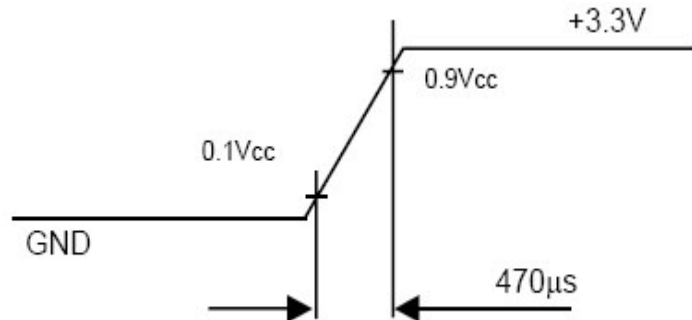

Note 7-3 :The specified power supply current is under the conditions at  $V_{DD} = 3.3\text{ V}$ ,  $T_a = 25 \pm 2\text{ }^\circ\text{C}$ , DC Current and  $f_v = 60\text{ Hz}$ , where as a power dissipation check pattern below is displayed.



a. White Pattern

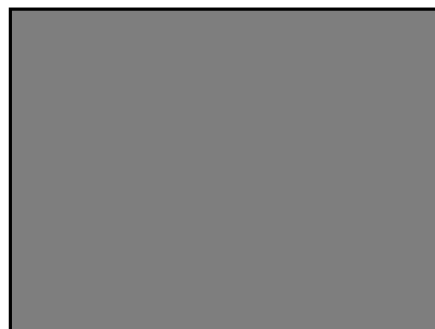

b. Black Pattern

7-2) Recommended Driver Condition for Backlight

Ta=25°C

Item	Symbol	Min.	Typ.	Max.	Unit	Remark
Lamp Current	I <sub>L</sub>	-	8.0	-	mA	Note 7-4
Lamp Voltage	V <sub>L</sub>	522	580	638	Vrms	I <sub>L</sub> =8mA
Lamp frequency	F	40	-	80	KHz	Note 7-5
Power Consumption	P <sub>L</sub>	4.18	4.64	5.1	W	Note 7-6
Starting voltage(25°C) (Reference Value)	V <sub>S</sub>	-	-	1210	Vrms	Note 7-7
Starting voltage(0°C) (Reference Value)	V <sub>S</sub>	-	-	1400	Vrms	Note 7-7

Note 7-4 : In order to satisfy the quality of B/L , no matter use what kind of inverter , the output lamp current must between Min. and Max. to avoid the abnormal display image caused by B/L.

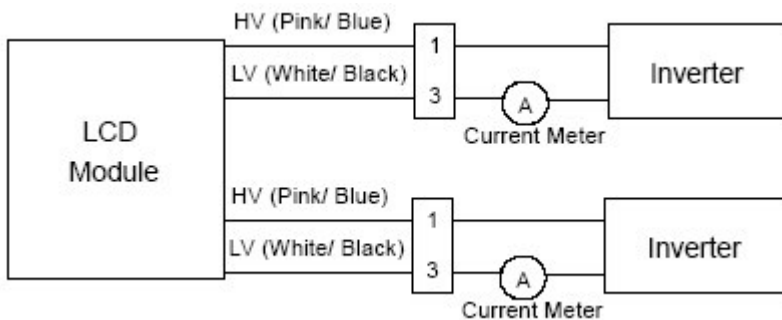

Note 7-5: The lamp frequency may produce interference with horizontal synchronization frequency from the display, which might cause line flow on the display. In order to avoid interference ,the lamp frequency should be detached from the horizontal synchronization frequency and its harmonics as far as possible.

Note 7-6 :Backlight lamp power consumption is calculated by I<sub>L</sub>×V<sub>L</sub>.

Note 7-7 : The” Max of starting voltage ” means the minimum voltage of inverter to turn on the CCFL. and it should be applied to the lamp for more than 1 second to start up. Otherwise the lamp may not be turned on.

**8. Pixel Arrangement**

The LCD module pixel arrangement is the stripe.

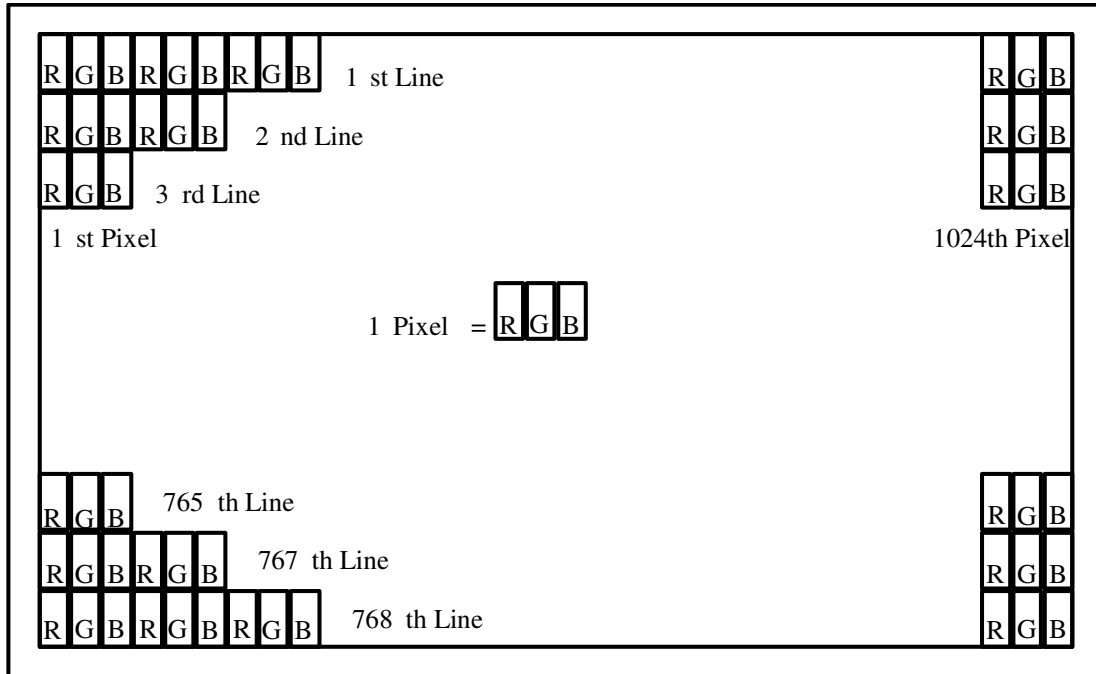

9. Display Color and Gray Scale Reference

Color		Data Signal																	
		Red						Green						Blue					
		R5	R4	R3	R2	R1	R0	G5	G4	G3	G2	G1	G0	B5	B4	B3	B2	B1	B0
Basic Colors	Black	0	0	0	0	0	0	0	0	0	0	0	0	0	0	0	0	0	0
	Red	1	1	1	1	1	1	0	0	0	0	0	0	0	0	0	0	0	0
	Green	0	0	0	0	0	0	1	1	1	1	1	1	0	0	0	0	0	0
	Blue	0	0	0	0	0	0	0	0	0	0	0	0	1	1	1	1	1	1
	Cyan	0	0	0	0	0	0	1	1	1	1	1	1	1	1	1	1	1	1
	Magenta	1	1	1	1	1	1	0	0	0	0	0	0	1	1	1	1	1	1
	Yellow	1	1	1	1	1	1	1	1	1	1	1	1	0	0	0	0	0	0
	White	1	1	1	1	1	1	1	1	1	1	1	1	1	1	1	1	1	1
Gray Scale Of Red	Red(0)/Dark	0	0	0	0	0	0	0	0	0	0	0	0	0	0	0	0	0	0
	Red(1)	0	0	0	0	0	1	0	0	0	0	0	0	0	0	0	0	0	0
	Red(2)	0	0	0	0	1	0	0	0	0	0	0	0	0	0	0	0	0	0
	:	:	:	:	:	:	:	:	:	:	:	:	:	:	:	:	:	:	:
	:	:	:	:	:	:	:	:	:	:	:	:	:	:	:	:	:	:	:
	:	:	:	:	:	:	:	:	:	:	:	:	:	:	:	:	:	:	:
	Red(61)	1	1	1	1	0	1	0	0	0	0	0	0	0	0	0	0	0	0
Red(62)	1	1	1	1	1	0	0	0	0	0	0	0	0	0	0	0	0	0	
Red(63)	1	1	1	1	1	1	0	0	0	0	0	0	0	0	0	0	0	0	
Gray Scale Of Green	Green(0)/Dark	0	0	0	0	0	0	0	0	0	0	0	0	0	0	0	0	0	0
	Green(1)	0	0	0	0	0	0	0	0	0	0	0	1	0	0	0	0	0	0
	Green(2)	0	0	0	0	0	0	0	0	0	0	1	0	0	0	0	0	0	0
	:	:	:	:	:	:	:	:	:	:	:	:	:	:	:	:	:	:	:
	:	:	:	:	:	:	:	:	:	:	:	:	:	:	:	:	:	:	:
	:	:	:	:	:	:	:	:	:	:	:	:	:	:	:	:	:	:	:
	Green(61)	0	0	0	0	0	0	1	1	1	1	0	1	0	0	0	0	0	0
Green(62)	0	0	0	0	0	0	1	1	1	1	1	0	0	0	0	0	0	0	
Green(63)	0	0	0	0	0	0	1	1	1	1	1	1	0	0	0	0	0	0	
Gray Scale Of Blue	Blue(0)/Dark	0	0	0	0	0	0	0	0	0	0	0	0	0	0	0	0	0	0
	Blue(1)	0	0	0	0	0	0	0	0	0	0	0	0	0	0	0	0	0	1
	Blue(2)	0	0	0	0	0	0	0	0	0	0	0	0	0	0	0	0	1	0
	:	:	:	:	:	:	:	:	:	:	:	:	:	:	:	:	:	:	:
	:	:	:	:	:	:	:	:	:	:	:	:	:	:	:	:	:	:	:
	:	:	:	:	:	:	:	:	:	:	:	:	:	:	:	:	:	:	:
	Blue(61)	0	0	0	0	0	0	0	0	0	0	0	0	1	1	1	1	0	1
Blue(62)	0	0	0	0	0	0	0	0	0	0	0	0	1	1	1	1	1	0	
Blue(63)	0	0	0	0	0	0	0	0	0	0	0	0	1	1	1	1	1	1	

Note 9-1: Low Level Voltage, 1: High Level Voltage

**10. Block Diagram**

10-1) TFT-module Block Diagram

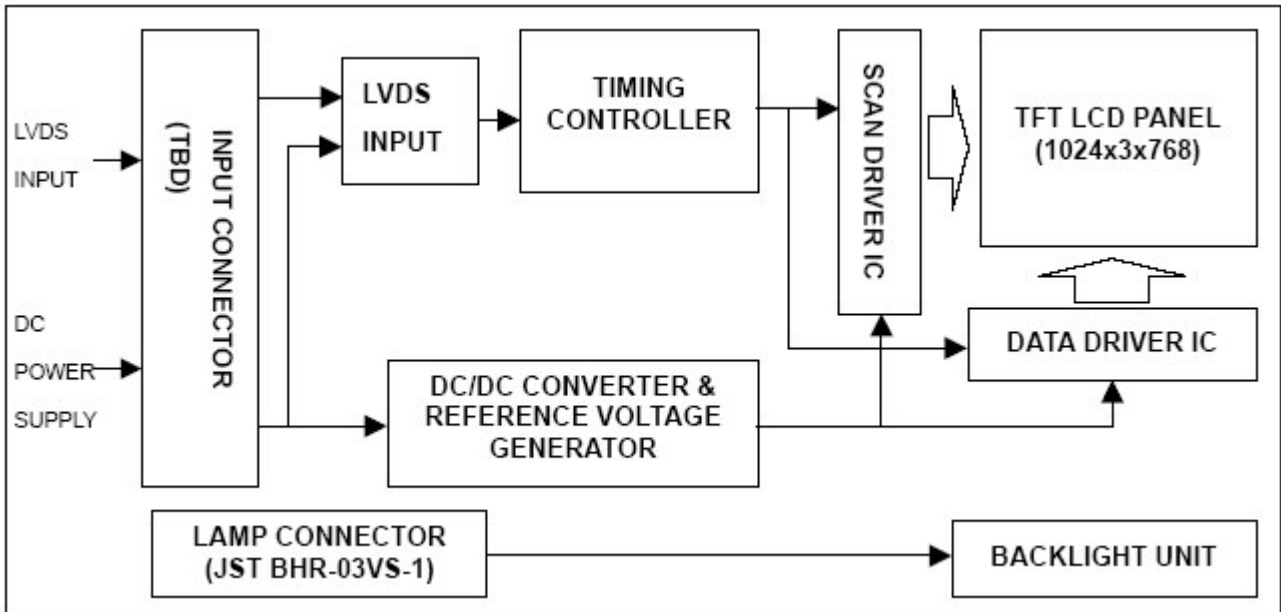

**11. Interface Timing**

11.1) Timing Parameters

Signal	Item	Symbol	Min.	Typ.	Max	Unit	Note
DCLK	Pixel Clock	1/Tc	-	65	80	MHz	-
DE	Vertical Total Time	T <sub>v</sub>	780	806	1200	T <sub>H</sub>	-
	Vertical Address Time	T <sub>vD</sub>	768	768	768	T <sub>H</sub>	-
	Horizontal Total Time	T <sub>H</sub>	1140	1344	1600	T <sub>C</sub>	-
	Horizontal Address Time	T <sub>HD</sub>	1024	1024	1024	T <sub>C</sub>	-

Note 11-1 : Because this module is operated by DE only mode, Hsync and Vsync input signals should be set to low logic level or ground. Otherwise, this module would operate abnormally.

**INPUT SIGNAL TIMING DIAGRAM**

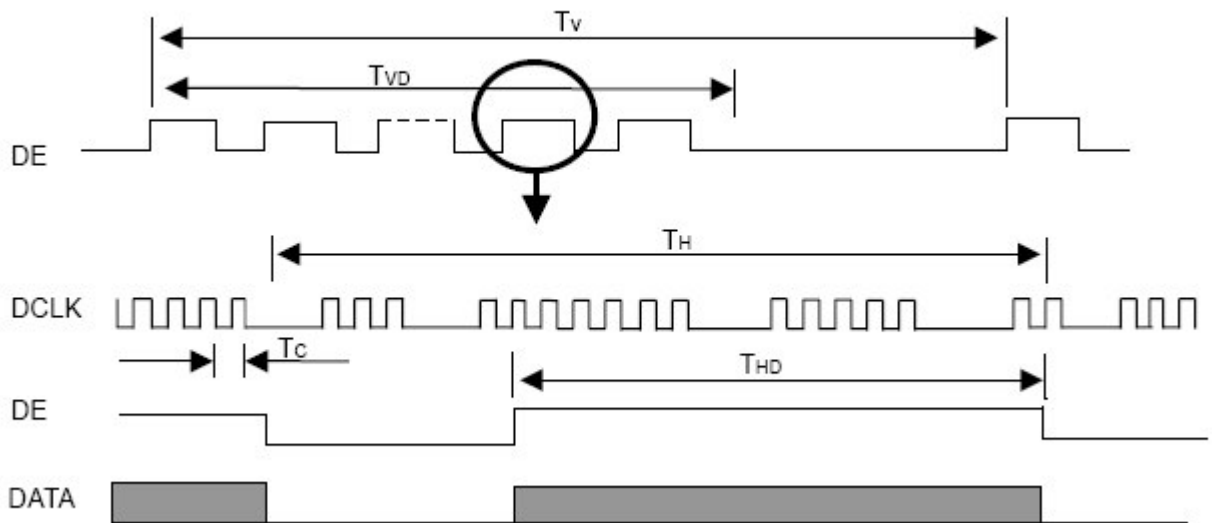

**TIMING DIAGRAM of LVDS**

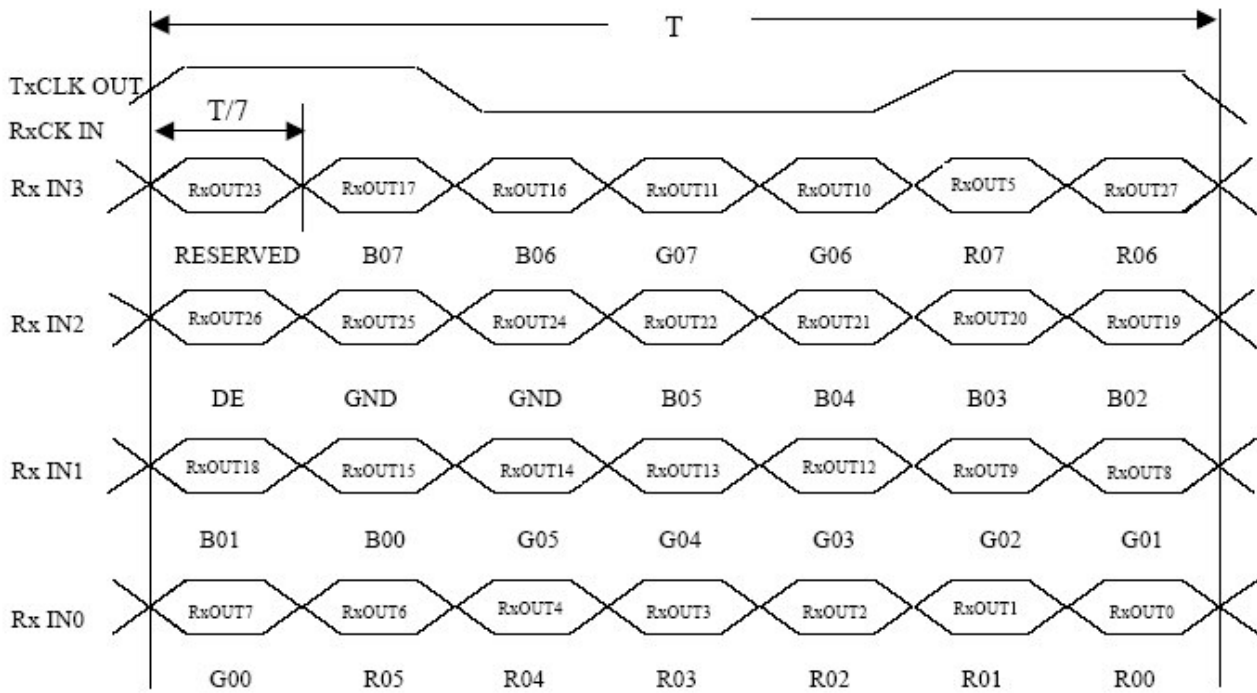

## 12. Power On Sequence

To prevent a latch-up or DC operation of LCD module, the power on/off sequence should follow the conditions shown in the following diagram.

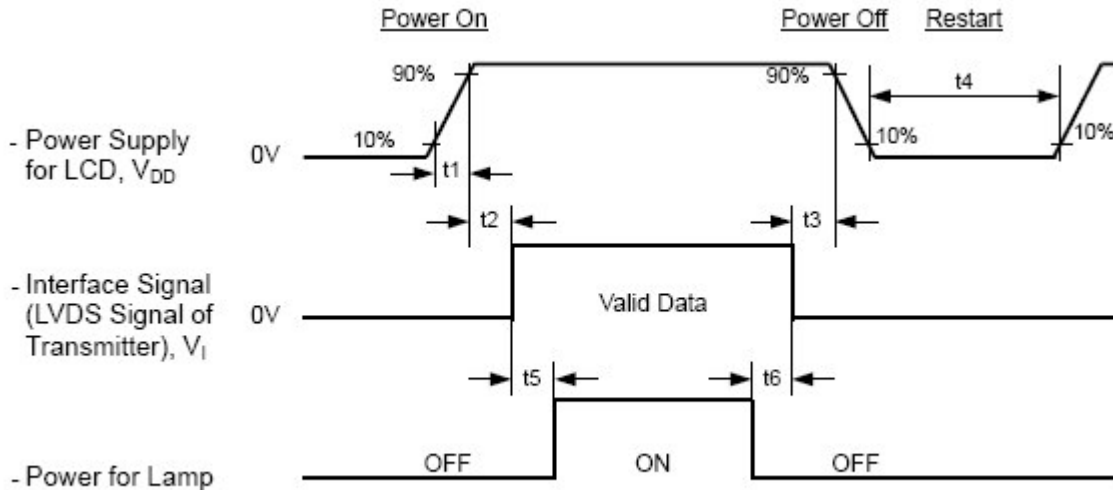

**Power ON/OFF Sequence**

Timing Specifications:

$$0.5 < t_1 \leq 10 \text{ ms}$$

$$0 < t_2 \leq 50 \text{ ms}$$

$$0 < t_3 \leq 50 \text{ ms}$$

$$t_4 \geq 500 \text{ ms}$$

$$t_5 \geq 200 \text{ ms}$$

$$t_6 \geq 200 \text{ ms}$$

Note12-1 Please avoid floating state of interface signal at invalid period.

Note 12-2 When the interface signal is invalid, be sure to pull down the power supply of LCD  $V_{DD}$  to 0 V.

Note12-3 The Backlight inverter power must be turned on after the power supply for the logic and the interface signal is valid. The Backlight inverter power must be turned off before the power supply for the logic and the interface signal is invalid.

**13. Optical Characteristics**

13-1) Specification:

Ta=25°C

Parameter	Symbol	Condition	MIN.	TYP.	MAX.	Unit	Remarks
Viewing Angle	Horizontal	$\theta$ 21.22	70	80	-	deg	Note 13-1
	Vertical	$\theta$ 12 (12 o'clock)	70	80	-	deg	
		$\theta$ 11 (6 o'clock)	70	80	-	deg	
Contrast Ratio	CR	$\theta = 0^\circ$	300	400		-	Note 13-2
Response time	Rise	Tr	-	8	13	ms	Note 13-3
	Fall	Tf	-	17	22	ms	
Brightness	L	$\theta = 0^\circ / \varphi = 0$	400	450	-	cd/m <sup>2</sup>	Note 13-4
Lamp Life Time	-	-	50000	-	-	hr	At 8mA
White Chromaticity	x	$\theta = 0^\circ / \varphi = 0$	0.283	0.313	0.343	-	
	y	$\theta = 0^\circ / \varphi = 0$	0.299	0.329	0.359	-	

All the optical measurement shall be executed 30 minutes after backlight being turn-on. The optical characteristics shall be measured in dark room (ambient illumination on panel surface less than 1 Lux). The measuring configuration shows as following figure.

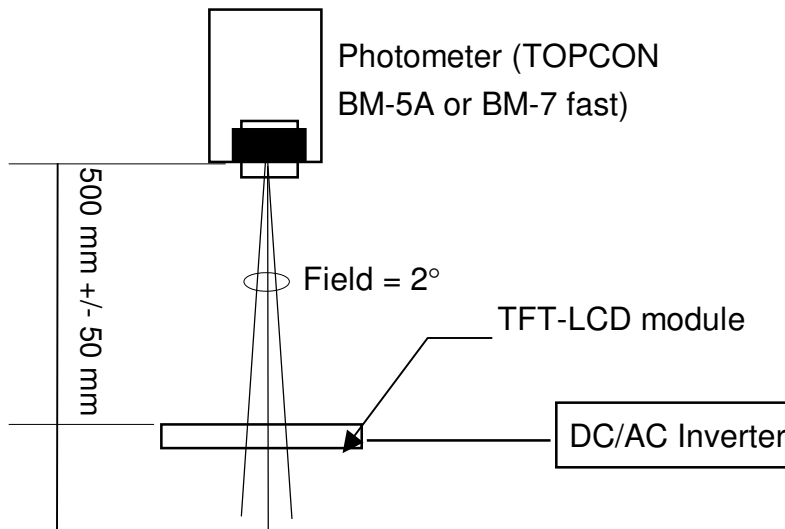

Optical characteristics measuring configuration

Note 13-1: Topcon BM-5A or BM-7 fast luminance meter 2° field of view is used in the testing (after 30 minutes' operation). The typical luminance value is measured at lamp current 8.0 mA.

Note 13-2: The definitions of viewing angles are as follow

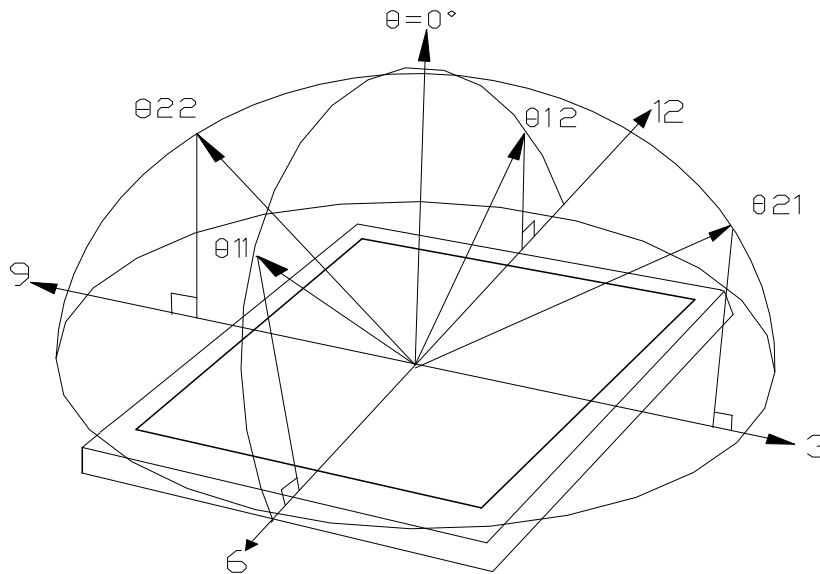

Note 13-3: Definition of Response Time  $T_r$  and  $T_f$

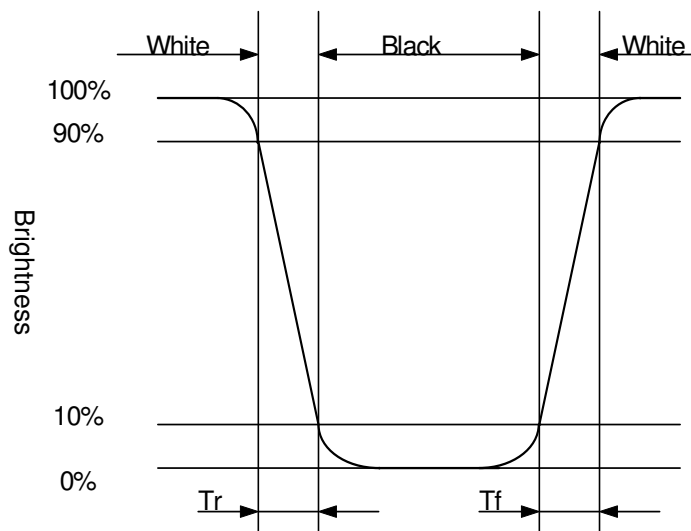

Note 13-4: The definition of contrast ratio  $CR = \frac{\text{Luminance at gray level 63}}{\text{Luminance at gray level 0}}$

## 14. Handling Cautions

### 14-1) Mounting of module

- a) Please power off the module when you connect the input/output connector.
- b) Please connect the ground pattern of the inverter circuit surely. If the connection is not perfect, some following problems may happen possibly.
  - 1.The noise from the backlight unit will increase.
  - 2.The output from inverter circuit will be unstable.
  - 3.In some cases a part of module will heat.
- c) Polarizer which is made of soft material and susceptible to flaw must be handled carefully.
- d) Protective film (Laminator) is applied on surface to protect it against scratches and dirt. It is recommended to peel off the laminator before use and taking care of static electricity.

### 14-2) Precautions in mounting

- a) When metal part of the TFT-LCD module (shielding lid and rear case) is soiled, wipe it with soft dry cloth.
- b) Wipe off water drops or finger grease immediately. Long contact with water may cause discoloration or spots.
- c) TFT-LCD module uses glass which breaks or cracks easily if dropped or bumped on hard surface. Please handle with care.
- d) Since CMOS LSI is used in the module. So take care of static electricity and earth yourself when handling.

### 14-3) Adjusting module

- a) Adjusting volumes on the rear face of the module have been set optimally before shipment.
- b) Therefore, do not change any adjusted values. If adjusted values are changed, the specifications described may not be satisfied.

### 14-4) Others

- a) Do not expose the module to direct sunlight or intensive ultraviolet rays for many hours.
- b) Store the module at a room temperature place.
- c) The voltage of beginning electric discharge may over the normal voltage because of leakage current from approach conductor by to draw lump read lead line around.
- d) If LCD panel breaks, it is possibly that the liquid crystal escapes from the panel. Avoid putting it into eyes or mouth. When liquid crystal sticks on hands, clothes or feet. Wash it out immediately with soap.
- e) Observe all other precautionary requirements in handling general electronic components.
- f) Please adjust the voltage of common electrode as material of attachment by 1 module.

**15. Reliability Test**

No	Test Item	Test Condition
1	High Temperature Storage Test	Ta = +80°C, 240 hrs
2	Low Temperature Storage Test	Ta = -40°C, 240 hrs
3	High Temperature Operation Test	Ta = +70°C, 240 hrs
4	Low Temperature Operation Test	Ta = -30°C, 240 hrs
5	High Temperature & High Humidity Operation Test	Ta = +40°C, 90%RH, 240 hrs (No Condensation)
6	Vibration Test (non-operating)	1.5G, 10 ~ 500 Hz, 30min/1cycle, 1.5mm max, 30min each X, Y, Z directions
7	Shock Test (non-operating)	220G, 11ms, 1 time each ±X, ±Y, ±Z directions

Ta: ambient temperature

Note : The protective film must be removed before temperature test.

[Criteria]

NO display malfunctions.

16. Packing Diagram

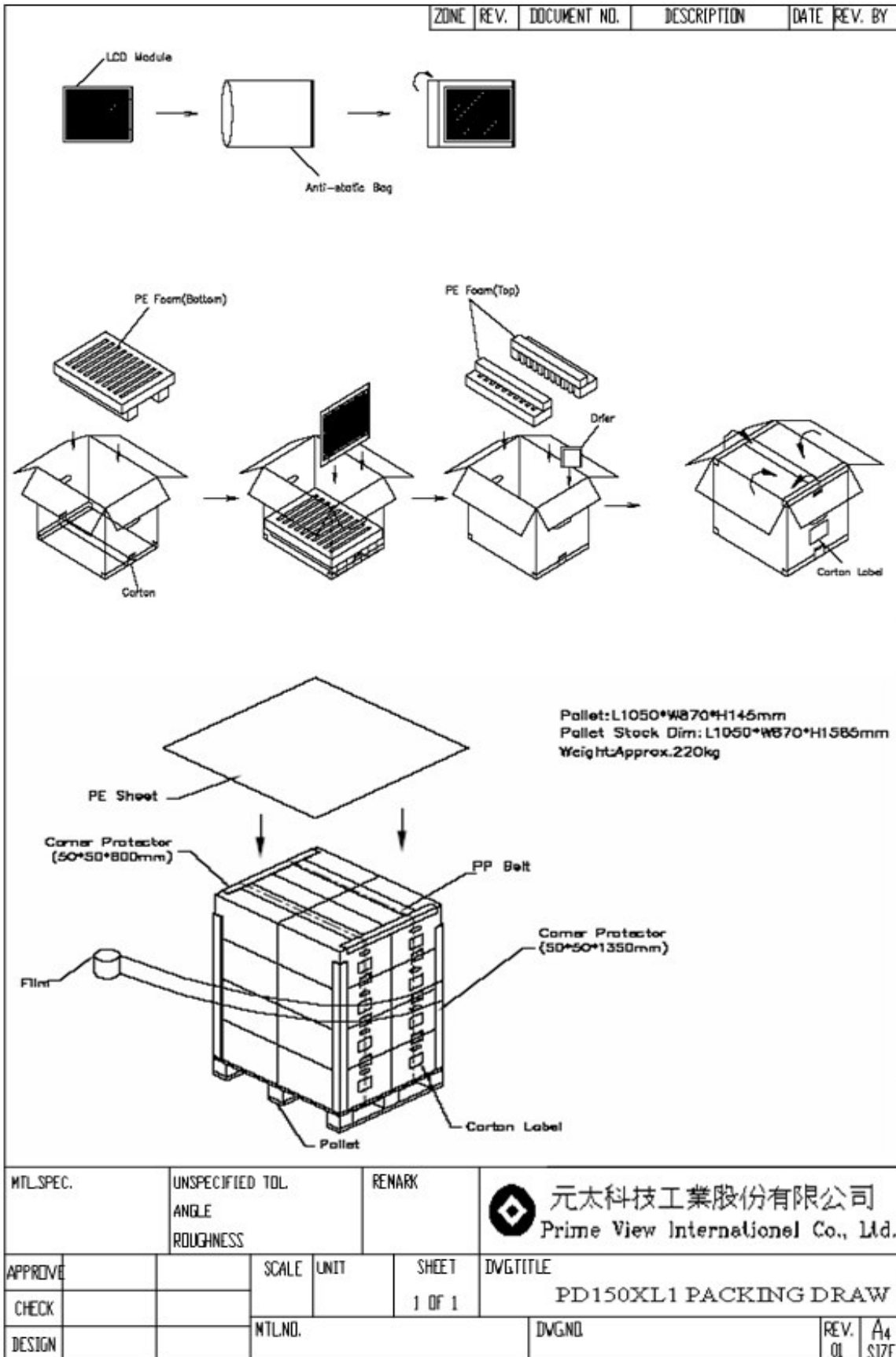

## Revision History

<b>Rev.</b>	<b>Issued Date</b>	<b>Revised Contents</b>
0.1	June, 22,06	Preliminary SPEC
0.2	July, 12, 06	Page 19 15.Reliability test Release test item and condition