

## SPECIFICATIONS

CUSTOMER	:	PTC
SAMPLE CODE	:	PS320240T-006-I-03
MASS PRODUCTION CODE	:	PH320240T-006-IP1Q
SAMPLE VERSION	:	01
SPECIFICATIONS EDITION	:	002
DRAWING NO. (Ver.)	:	LMD- PH320240T-006-IP1Q (Ver:001)
PACKAGING NO. (Ver.)	:	PKG- PH320240T-006-IP1Q (Ver:001)

**Customer Approved**

**Date:**

Approved	Checked	Designer
<b>Oliver Huang</b> 黃秋源		<b>Jared Hsieh</b> 謝世民

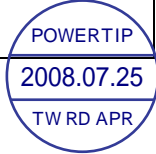

- Preliminary specification for design input
- Specification for sample approval

### POWERTIP TECH. CORP.

**Headquarters:**  
 No.8, 6<sup>th</sup> Road, Taichung Industrial Park,  
 Taichung, Taiwan  
 台中市 407 工業區六路 8 號

TEL: 886-4-2355-8168  
 FAX: 886-4-2355-8166

E-mail: [sales@powertip.com.tw](mailto:sales@powertip.com.tw)  
 Http://www.powertip.com.tw



## Contents

### 1. SPECIFICATIONS

- 1.1 Features
- 1.2 Mechanical Specifications
- 1.3 Absolute Maximum Ratings
- 1.4 DC Electrical Characteristics
- 1.5 Optical Characteristics
- 1.6 Backlight Characteristics
- 1.7 Touch Panel Characteristics

### 2. MODULE STRUCTURE

- 2.1 Counter Drawing
- 2.2 Interface Pin Description
- 2.3 Timing Characteristics
  - 2.3.1 SPI Read
  - 2.3.2 SPI Write
  - 2.3.3 SPI Timing Table
- 2.4 Power Sequence
  - 2.4.1 Power up sequence
  - 2.4.2 Power down sequence
- 2.5 Reference Initial code

### 3. QUALITY ASSURANCE SYSTEM

- 3.1 Quality Assurance Flow Chart
- 3.2 Inspection Specification

### 4. RELIABILITY TEST

- 4.1 Reliability Test Condition

### 5. PRECAUTION RELATING PRODUCT HANDLING

- 5.1 Safety
- 5.2 Handling
- 5.3 Storage
- 5.4 Terms of Warranty

#### Appendix : LCM Drawing Packaging

Note : For detailed information please refer to IC data sheet :  
Primacy(TFT LCD): Himax: HX8238-A

## 1. SPECIFICATIONS

### 1.1 Features

#### Main LCD panel

Item	Standard Value
Display Type	320(R · G · B) * 240 Dots
LCD Type	Normally white , Transmissive type
Screen size(inch)	3.5 inch
Viewing Direction	6 O'clock
Color configuration	RGB-Strip
Backlight	LED
Interface	Digital 24-bits RGB
Other(controller/driver IC)	<b>Himax: HX8238-A</b>
ROHS	THIS PRODUCT CONFORMS THE ROHS OF PTC Detail information please refer web side : <a href="http://www.powertip.com.tw/news/LatestNews.asp">http://www.powertip.com.tw/news/LatestNews.asp</a>

### 1.2 Mechanical Specifications

Item	Standard Value	Unit
Outline Dimension	76.9(W) * 63.9 (L) * 4.75 (H)(MAX)	mm

#### LCD panel

Item	Standard Value	Unit
Viewing Area	72.88 (W) * 55.36 (L)	mm
Active Area	70.08 (W) * 52.56 (L)	mm

#### Touch panel

Item	Standard Value	Unit
Viewing Area	72.0 (W) x 54.56 (H)	mm
Active Area	70.8 (W) x 53.26 (L)	mm

Note : For detailed information please refer to LCM drawing

### 1.3 Absolute Maximum Ratings

#### Module

Item	Symbol	Condition	Min.	Max.	Unit
System Power Supply Voltage	VDDIO	VSS=0	-0.3	4.0	V
Operating Temperature	T <sub>OP</sub>	-	-20	70	°C
Storage Temperature	T <sub>ST</sub>	-	-30	80	°C

### 1.4 DC Electrical Characteristics

#### Module

VSS = 0V, Ta = 25°C

Item	Symbol	Condition	Min.	Typ.	Max.	Unit
Power Supply Voltage1	VDDIO	-	3.0	3.3	3.6	V
V <sub>COM</sub> High Voltage	V <sub>COMH</sub>	-	2.5	(3.6)	4.5	V
V <sub>COM</sub> Low Voltage	V <sub>COML</sub>	-	-3	(-2.4)	0	V
Supply Current	IDD	VDD = 3.3 V Pattern= black *1	-	5.5	8.5	mA

Note1:Maximum current display

## 1.5 Optical Characteristics

### TFT LCD Module

VDDIO =3.3V, Ta=25°C

Item	Symbol	Condition	Min.	Typ.	Max.	unit	-	
Response time	Tr+ Tf	Ta = 25°C θX, θY = 0°	-	50	70	ms	Note2	
Viewing angle	Top	θY+	-	45	-	Deg.	Note4	
	Bottom	θY-	-	50	-			
	Left	θX-	-	50	-			
	Right	θX+	-	50	-			
Contrast ratio	CR	Ta = 25°C θX, θY = 0°	200	250	-	-	Note3	
Color of CIE Coordinate (With B/L&T/P)	White	X	-	0.248	0.298	0.348	-	Note1
		Y	-	0.276	0.326	0.376		
	Red	X	-	0.571	0.621	0.671		
		Y	-	0.313	0.363	0.413		
	Green	X	-	0.279	0.329	0.379		
		Y	-	0.546	0.596	0.646		
	Blue	X	-	0.093	0.143	0.193		
		Y	-	0.034	0.084	0.134		
Average Brightness Pattern=white display (With B/L&T/P) *1	IV	IF=20 mA	190	275	-	cd/m <sup>2</sup>		
Uniformity (With B/L&T/P)*2	△B	IF=20 mA	70	-	-	%		

Note 1:

\*1 :  $\Delta B = B(\text{min}) / B(\text{max}) * 100\%$

\*2 : Measurement Condition for Optical Characteristics:

a : Environment:  $25^{\circ}\text{C} \pm 5^{\circ}\text{C}$  /  $60 \pm 20\%$  R.H , no wind , dark room below 10 Lux at typical lamp current and typical operating frequency.

b : Measurement Distance:  $500 \pm 50$  mm , ( $\theta = 0^{\circ}$ )

c : Equipment: TOPCON BM-7 fast , (field  $1^{\circ}$ ) , after 10 minutes operation.

d : The uncertainty of the C.I.E coordinate measurement  $\pm 0.01$  , Average Brightness  $\pm 4\%$

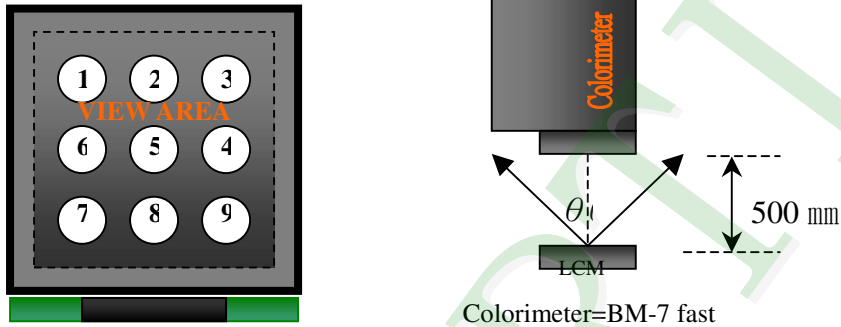

To be measured at the center area of panel with a viewing cone of  $1^{\circ}$  by Topcon luminance meter BM-7, after 10 minutes operation (module)

Note2: Definition of response time:

The output signals of photo detector are measured when the input signals are changed from "black" to "white"(falling time) and from "white" to "black"(rising time), respectively. The response time is defined as the time interval between the 10% and 90% of Amplitudes.

Refer to figure as below:

Normally White

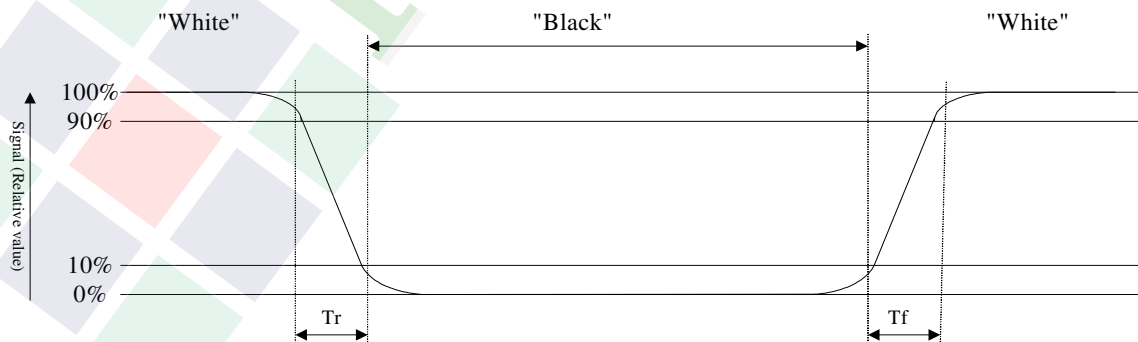

## Normally Black

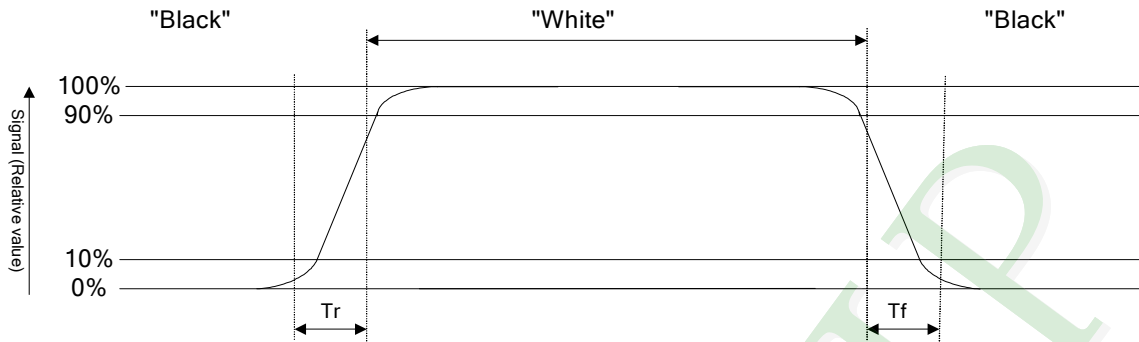

Note3: Definition of contrast ratio:

Contrast ratio is calculated with the following formula

$$\text{Contrast ratio (CR)} = \frac{\text{Photo detector output when LCD is at "White" state}}{\text{Photo detector output when LCD is at "Black" state}}$$

Note4: Definition of viewing angle:

Refer to figure as below:

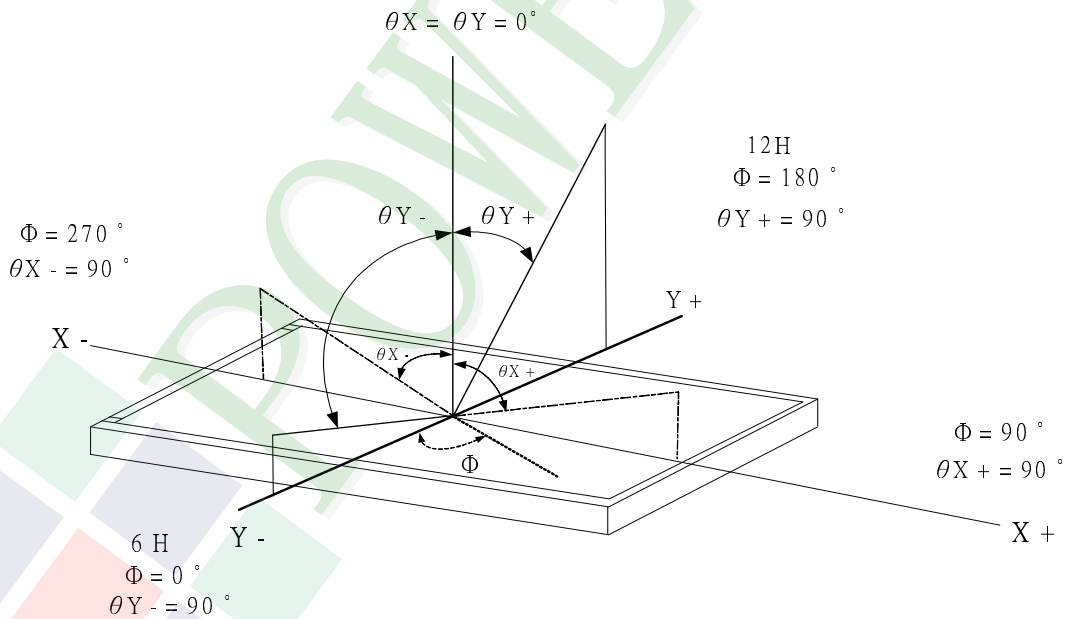

## 1.6 Backlight Characteristics

### Maximum Ratings

Item	Symbol	Conditions	Min.	Max.	Unit
Power Dissipation	PD	Ta =25°C	—	0.12	W

### Electrical / Optical Characteristics

Item	Symbol	Conditions	Min.	Typ.	Max.	Unit
Forward Voltage	VF	IF= 20 mA	16.8	19.2	19.6	V
Average Brightness (without LCD)	IV		3500	4300	—	cd/m <sup>2</sup>
CIE Color Coordinate (Without LCD)	X		—	0.30	—	-
	Y		—	0.30	—	
Color	White					

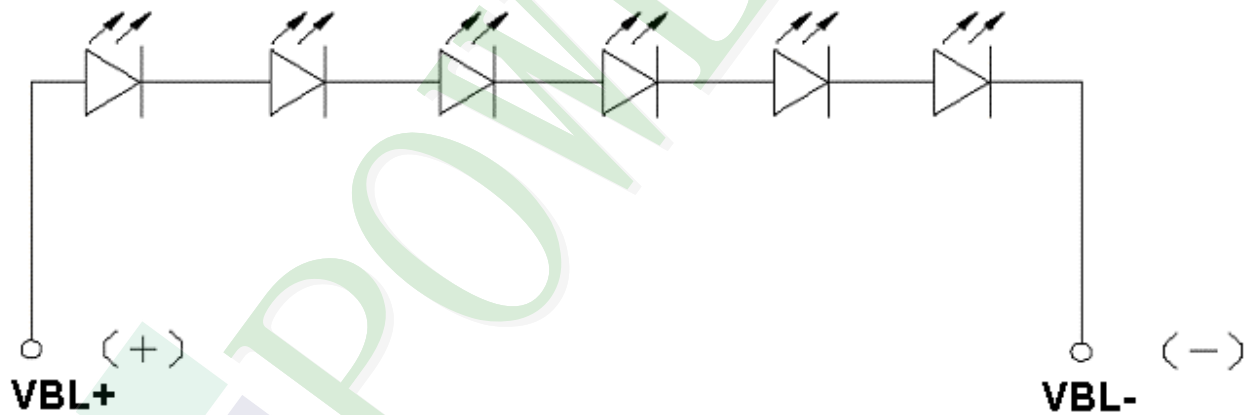

## 1.7 Touch Panel Characteristics

1	Input Method and Activation Force	Stylus < 80grams and Finger < 80grams
2	Typical Optical Characteristics	Visible Light Transmission : >80% Haze : 10%(typ)
3	Electrical Specifications	1. Operating Voltage 7V or less 2. Circuit close resistance X : 300~900 ohm Y : 200~800 ohm 3. Circuit open resistance > 10 Mohm at 25V DC 4. Contact bounce < 20ms 5. Operative resistance ≤ 2.0 kohm
4	Linearity Tolerance	X≤1.5% (maximum), Y≤1.5% (maximum)
5	Environment Specification	Operating Temperature -20°C ~ +70°C (Operating Humidity: 20%~90% RH) Storage Temperature -30°C ~ +80°C (Storage Humidity: 10%~90% RH)

## 2.1 Counter Drawing

### 2.1.1 LCM Mechanical Diagram

\* See Appendix

### 2.1.2 Block Diagram

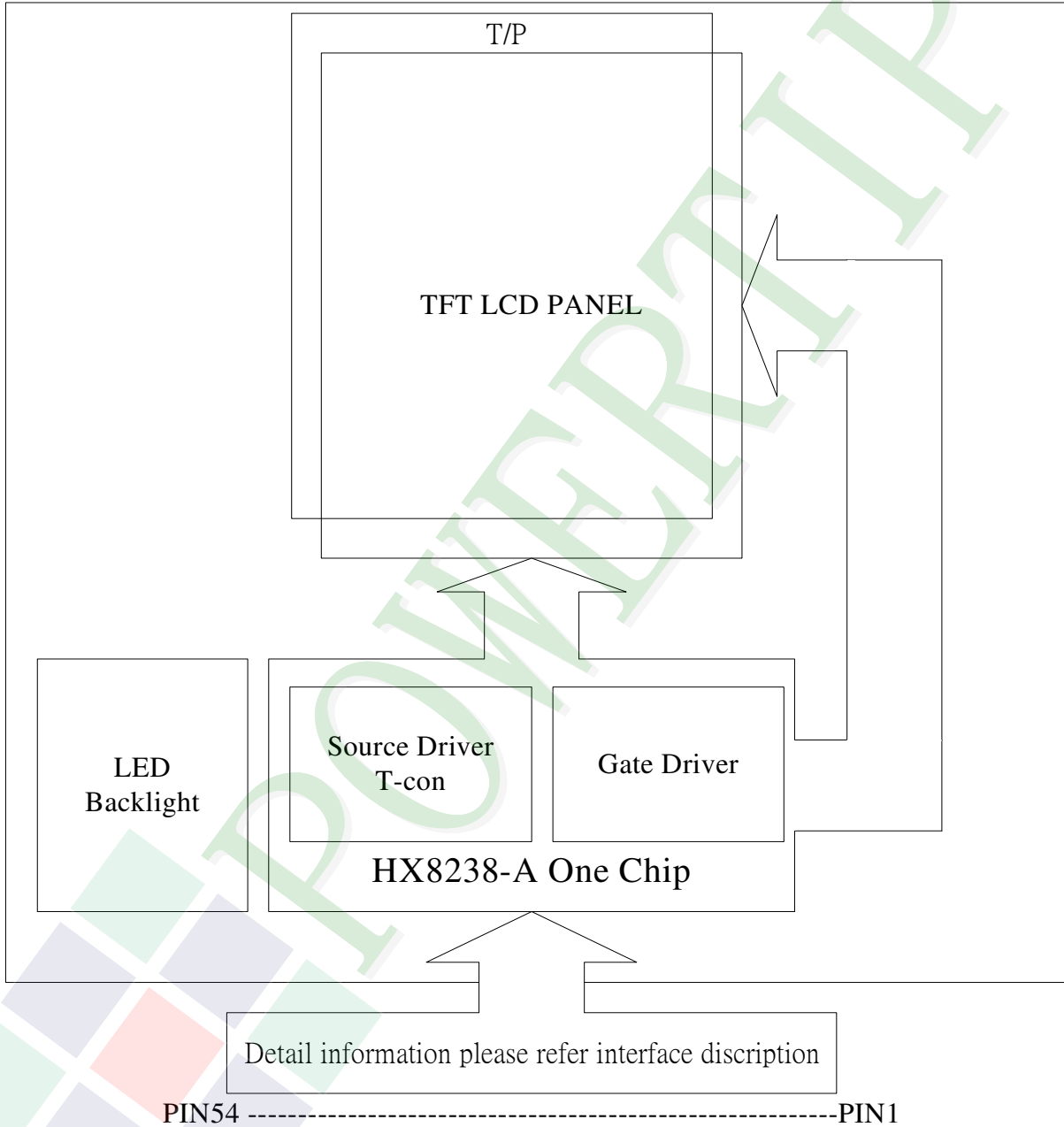

## 2.2 Interface Pin Description

Pin No.	Symbol	Function
1	VBL-	Power supply for LED Backlight cathode input
2	VBL-	Power supply for LED Backlight cathode input
3	VBL+	Power supply for LED Backlight anode input
4	VBL+	Power supply for LED Backlight anode input
5	NC	Not used , Must be open
6	/RESET	Hardware reset
7	NC	Not used , Must be open. (Output Pin ,POL output.)
8	Y1	Touch panel TOP
9	X1	Touch panel RIGHT
10	Y2	Touch panel BOTTOM
11	X2	Touch panel LEFT
12	B0	Blue data bit 0
13	B1	Blue data bit 1
14	B2	Blue data bit 2
15	B3	Blue data bit 3
16	B4	Blue data bit 4
17	B5	Blue data bit 5
18	B6	Blue data bit 6
19	B7	Blue data bit 7
20	G0	Green data bit 0
21	G1	Green data bit 1
22	G2	Green data bit 2
23	G3	Green data bit 3
24	G4	Green data bit 4
25	G5	Green data bit 5
26	G6	Green data bit 6
27	G7	Green data bit 7
28	R0	Red data bit 0
29	R1	Red data bit 1
30	R2	Red data bit 2

31	R3	Red data bit 3
32	R4	Red data bit 4
33	R5	Red data bit 5
34	R6	Red data bit 6
35	R7	Red data bit 7
36	HSYNC	Horizontal sync input
37	VSYNC	Vertical sync input
38	DOTCLK	Dot data clock
39	VDDIO	Digital power
40	VDDIO	Digital power
41	VDDIO	Digital power
42	VDDIO	Digital power
43	SPENA	Serial port data enable signal
44	NC	Not used , Must be open
45	NC	Not used , Must be open (Output Pin , V <sub>GL</sub> , Gate off power.)
46	NC	Not used , Must be open
47	NC	Not used , Must be open (Output Pin , V <sub>GH</sub> , Gate on power.)
48	SHUT	Display shut down pin to put the driver into sleep mode. A sharp falling edge must be provided to such pin when IC power on. Internal pull low. - Connect to VDDIO for sleep mode - Connect to VSS for normal operating mode (Refer to Power Up Sequence)
49	SPCLK	Serial data clock
50	SPDAT	Serial data
51	NC	Not used , Must be open (Output Pin , VCOM power.)
52	ENB	Data enable control
53	VSS	Ground
54	VSS	Ground

## 2.3 Timing Characteristics

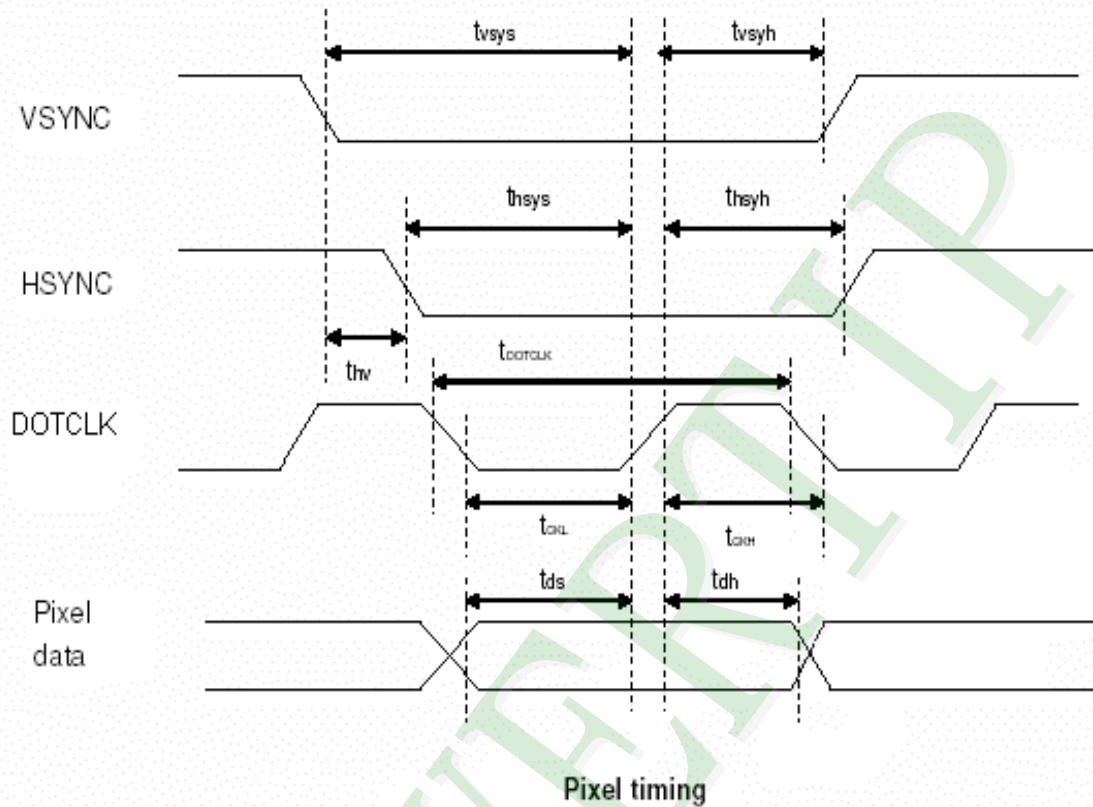

Characteristics	Symbol	Min		Typ		Max		Unit
		24 bit	8 bit	24 bit	8 bit	24 bit	8 bit	
DOTCLK Frequency	fDOTCLK	-		6.5	19.5	10	30	MHz
DOTCLK Period	tDOTCLK	100	33.3	154	51.3	-		ns
Vertical Sync Setup Time	tvsys	20	10	-		-		ns
Vertical Sync Hold Time	tvsyh	20	10	-		-		ns
Horizontal Sync Setup Time	thsys	20	10	-		-		ns
Horizontal Sync Hold Time	thsyh	20	10	-		-		ns
Phase difference of Sync Signal Falling Edge	thv	1		-		240		tDOTCLK
DOTCLK Low Period	tCKL	50	15	-		-		ns
DOTCLK High Period	tCKH	50	15	-		-		ns
Data Setup Time	tds	12	10	-		-		ns
Data hold Time	tdh	12	10	-		-		ns
Reset pulse width	tRES	10		-		-		us

Note: External clock source must be provided to DOTCLK pin of HX8238-A. The driver will not operate if absent of the clocking signal.

### Pixel timing

Note : The interface of this module can drive by digital 24-bit data.

### First Transmission (Register)

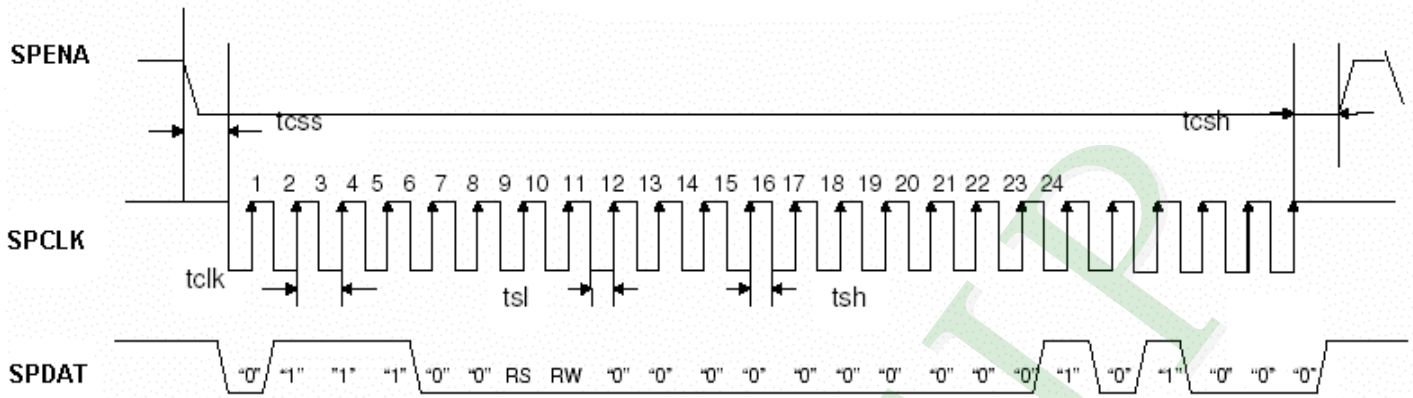

### Second Transmission (Data)

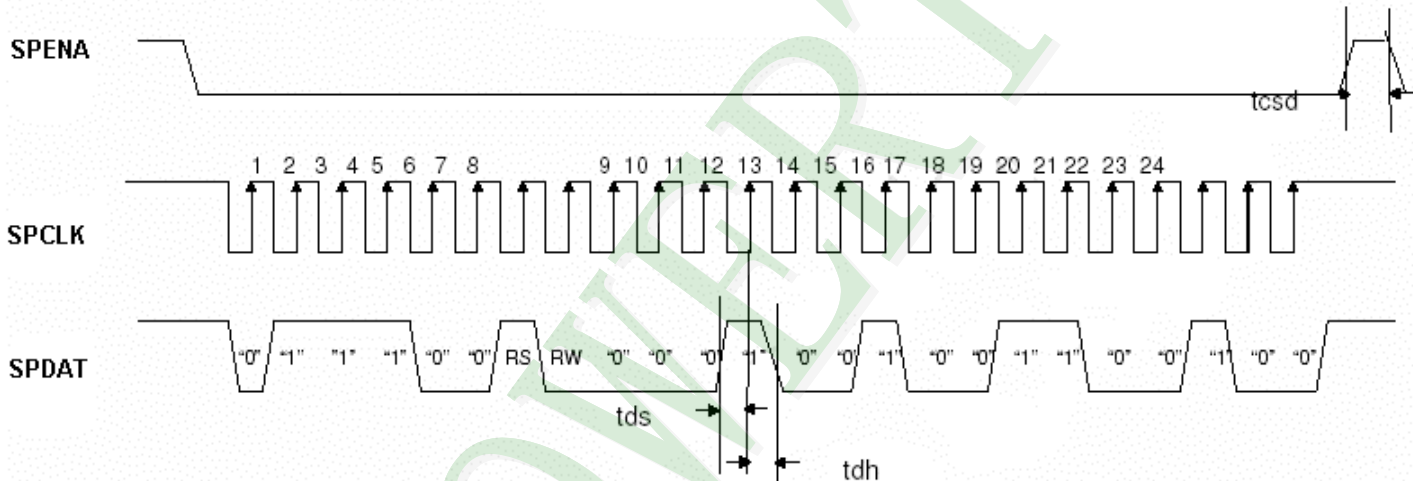

**Note:** The example transmit "0x1264h" to register R28h.  
SPID connected to VSS.

### SPI interface timing diagram & transaction example

Characteristics	Symbol	Min	Typ	Max	Unit
Serial Clock Frequency	fclk	-	-	20	MHz
Serial Clock Cycle Time	tclk	50	-	-	ns
Clock Low Width	tsl	25	-	-	ns
Clock High Width	tsh	25	-	-	ns
Chip Select Setup Time	tcss	0	-	-	ns
Chip Select Hold Time	tcsh	10	-	-	ns
Chip Select High Delay Time	tcsd	20	-	-	ns
Data Setup Time	tds	5	-	-	ns
Data Hold Time	tdh	10	-	-	ns

### SPI timing

### 2.3.1 SPI Read

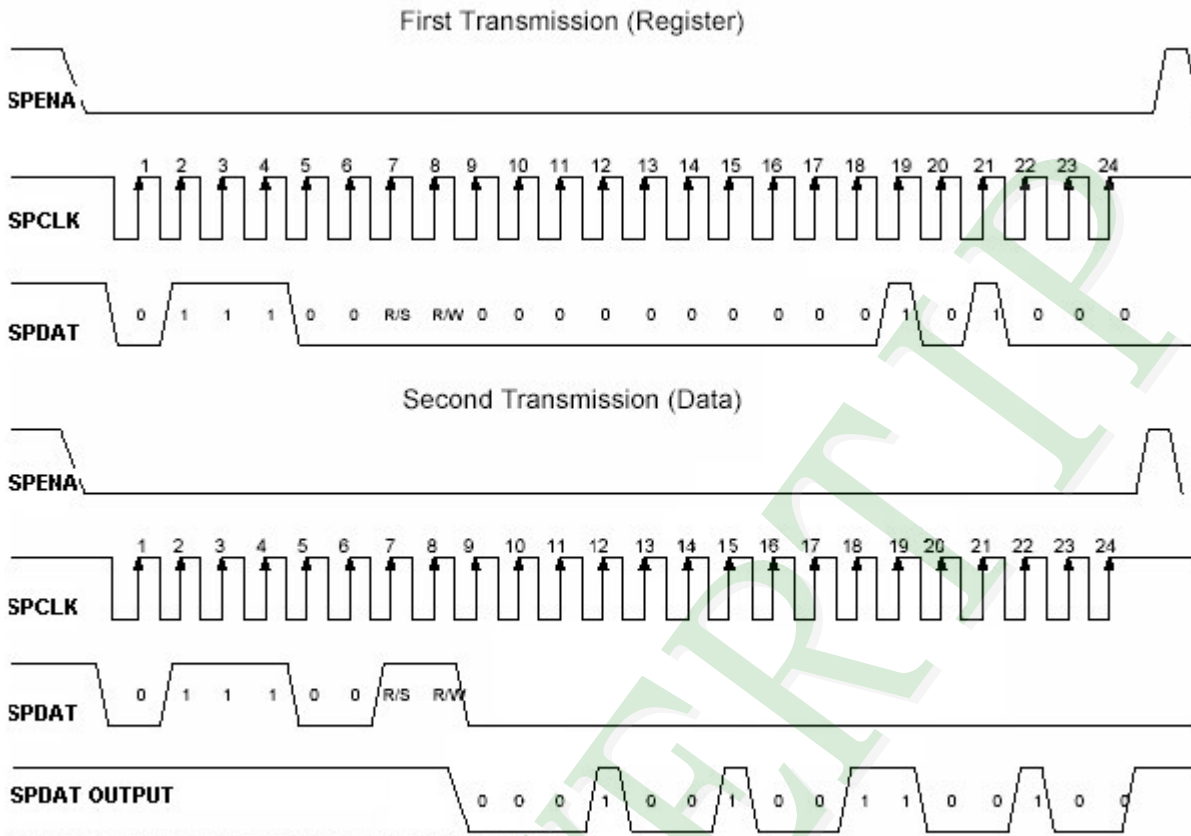

SPI interface Timing Diagram & Read SPI Example

## 2.3.2 SPI Write

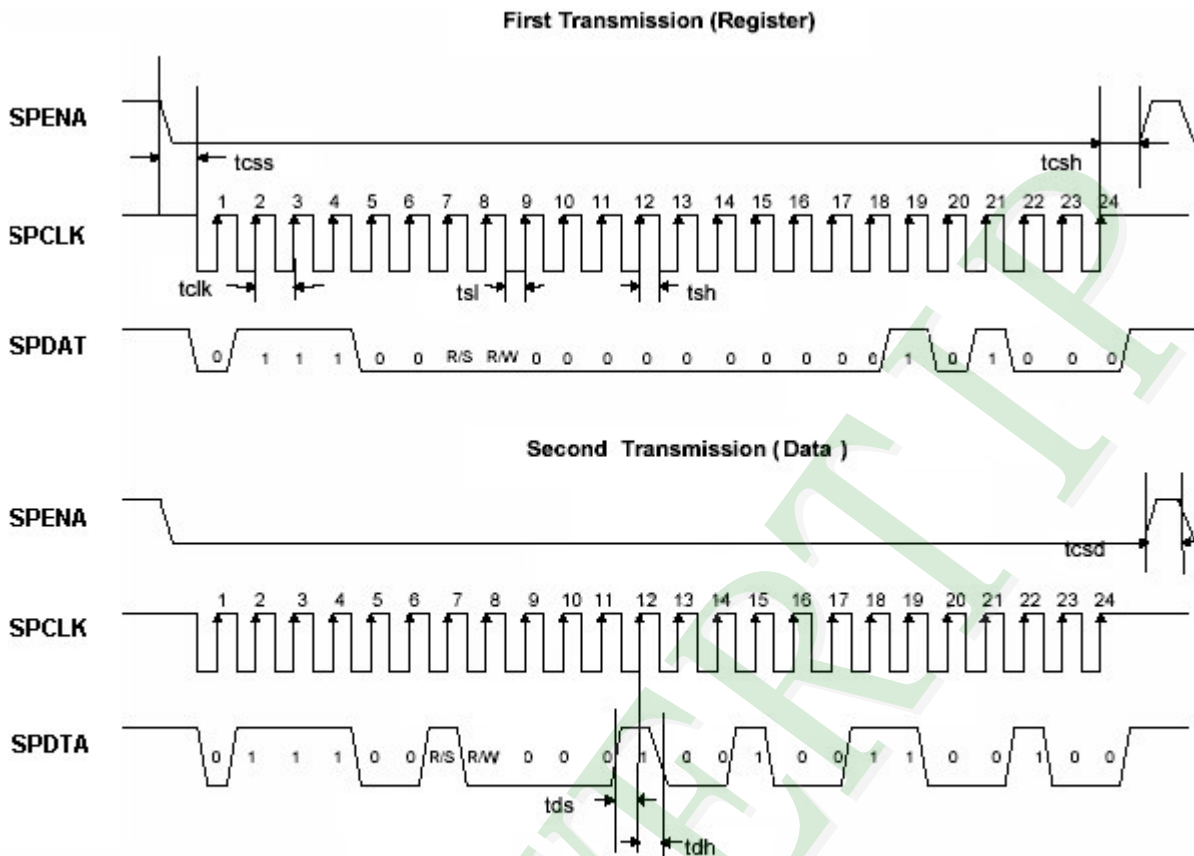

Note: The example writes "0x1264h" to register R28h.  
SPID connected to VSS.

SPI interface Timing Diagram & Write SPI Example

## 2.3.3 SPI Timing Table

Characteristics	Symbol	Min.	Typ.	Max.	Unit
Serial Clock Frequency	fclk	-	-	20	MHz
Serial Clock Cycle Time	tclk	50	-	-	ns
Clock Low Width	tsl	25	-	-	ns
Clock High Width	tsh	25	-	-	ns
Clock Rising Time	trs	-	-	30	ns
Clock Falling Time	tfl	-	-	30	ns
Chip Select Setup Time	tcss	0	-	-	ns
Chip Select Hold Time	tcsh	10	-	-	ns
Chip Select High Delay Time	tcsd	20	-	-	ns
Data Setup Time	tds	5	-	-	ns
Data Hold Time	tdh	10	-	-	ns

SPI Timing

## 2.4 Power Sequence

### 2.4.1 Power up sequence

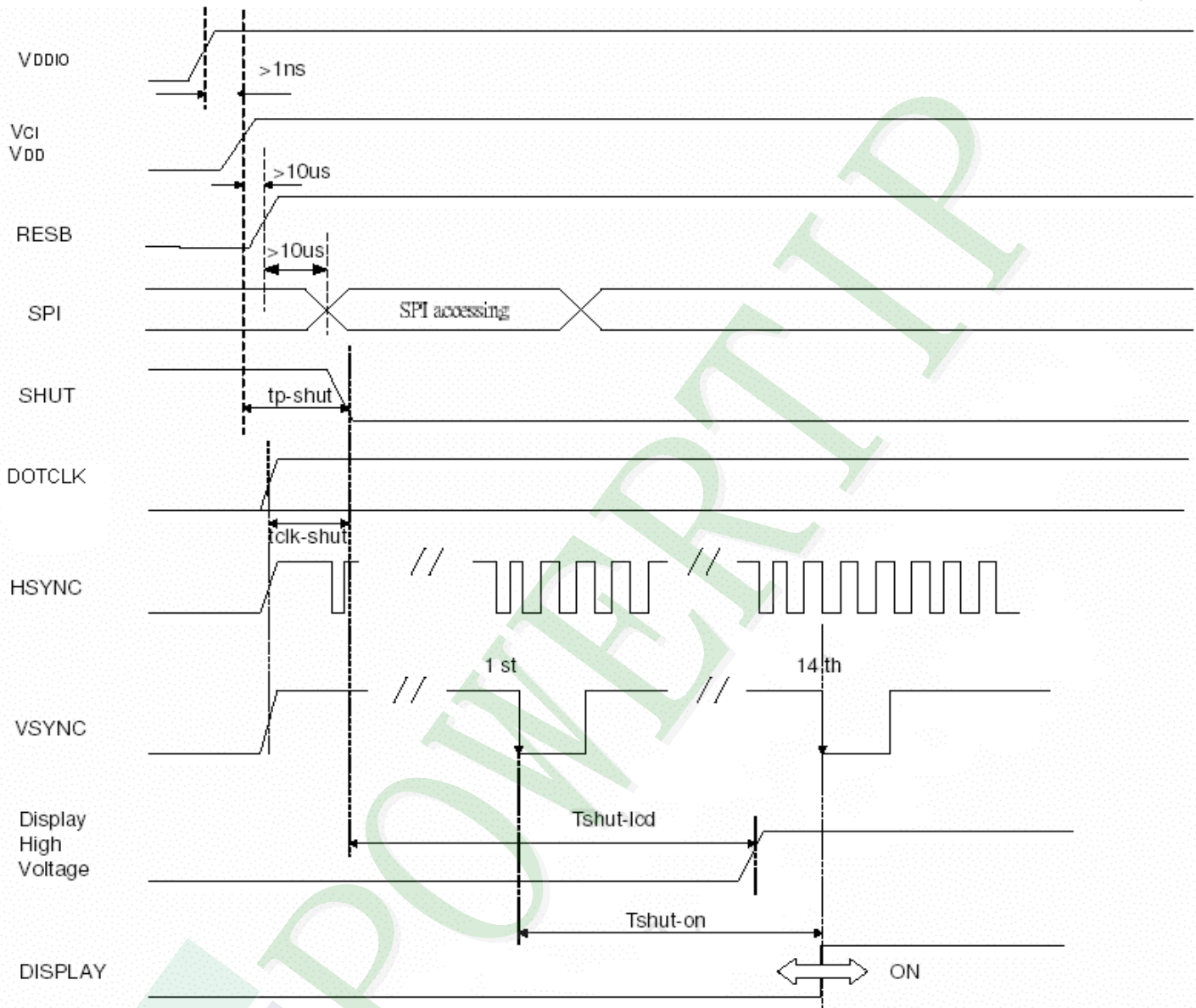

Characteristics	Symbol	Min	Typ	Max	Units
VDDD / VDDIO on to falling edge of SHUT	tp-shut	1	-	-	us
DOTCLK	tclk-shut	1	-	-	clk
Falling edge of SHUT to LCD power on	tshut-lcd	-	-	128	ms
Falling edge of SHUT to display start	tshut-on	-	-	14	frame
- 1 line: 408 clk		-	166	232.4	ms
- 1 frame: 262 line - DOTCLK = 6.5MHz		-	-	-	-

**Note:** It is necessary to input DOTCLK before the falling edge of SHUT.  
Display starts at 10th falling edge of VSTNC after the falling edge of SHUT.

Note : 1、The voltage of VDD be boosted from VDDIO.

## 2.4.2 Power down sequence

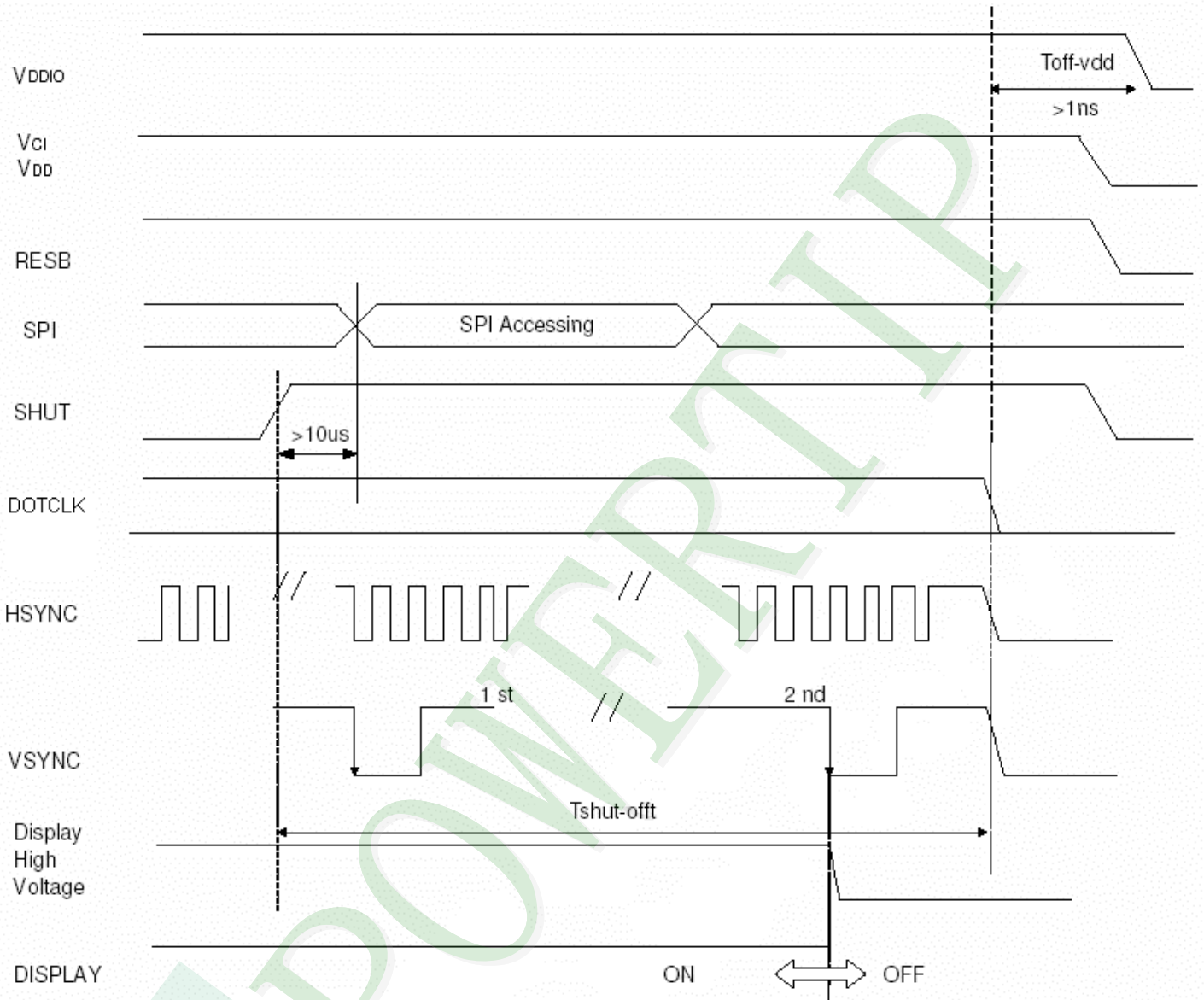

Characteristics	Symbol	Min	Typ	Max	Uni
Rising edge of SHUT to display off	tshut-off	2	-	-	frame
- 1 line: 408 clk		33.4	-	-	ms
- 1 frame: 262 line					
- DOTCLK = 6.5MHz					
Input-signal-off to VDDD / VDDIO off	toff-vdd	1	-	-	us

**Note:** DOTCLK must be maintained at least 2 frames after the rising edge of SHUT.

Display become off at the 2nd falling edge of VSTNC after the falling edge of SHUT.

If RESET signal is necessary for power down, provide it after the 2-frames-cycle of the SHUT period.

Note : 1 、 The voltage of VDD be boosted from VDDIO.

## 2.5 Reference Initial code

Register(0x0001);  
Data(0x7300);

Register(0x0002);  
Data(0x0200);

Register(0x0003);  
Data(0x6164);

Register(0x0004);  
Data(0x04C7);

Register(0x0005);  
Data(0xFC80);

Register(0x00,0x0A);           //Contrast/Brightness control;  
Data(0x4008);

Register(0x00,0x0D);           //Power control(2);  
Data(0x3229);

Register(0x00,0x0E);           //Power control(3);VOML  
Data(0x3200);

\*\*\*\*\*

Flicker!!! Plz , download below.

Register(0x00,0x1E);           //Power control(4);COMH  
Data(0x00DF);

\*\*\*\*\*

### 3. QUALITY ASSURANCE SYSTEM

#### 3.1 Quality Assurance Flow Chart

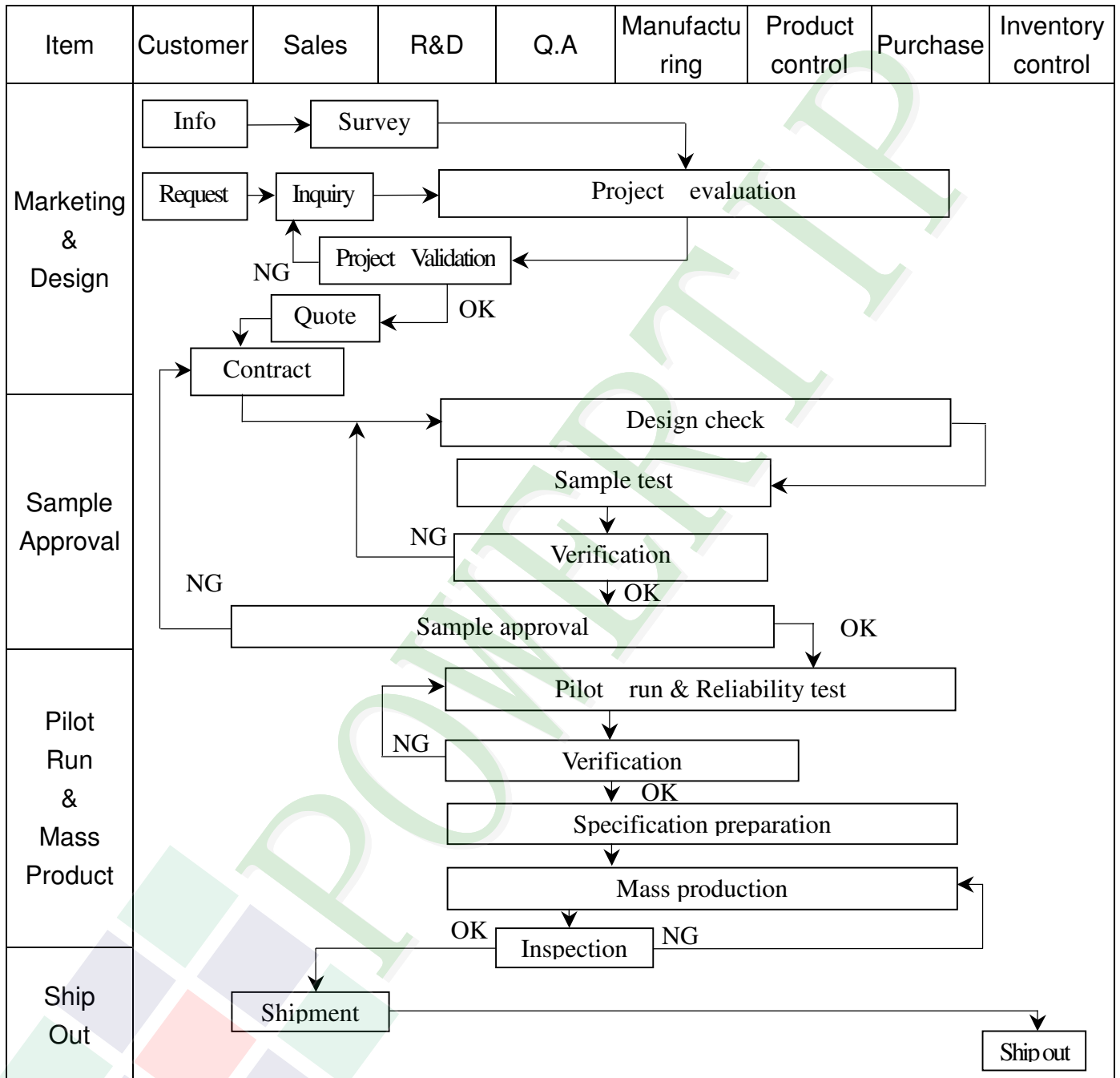

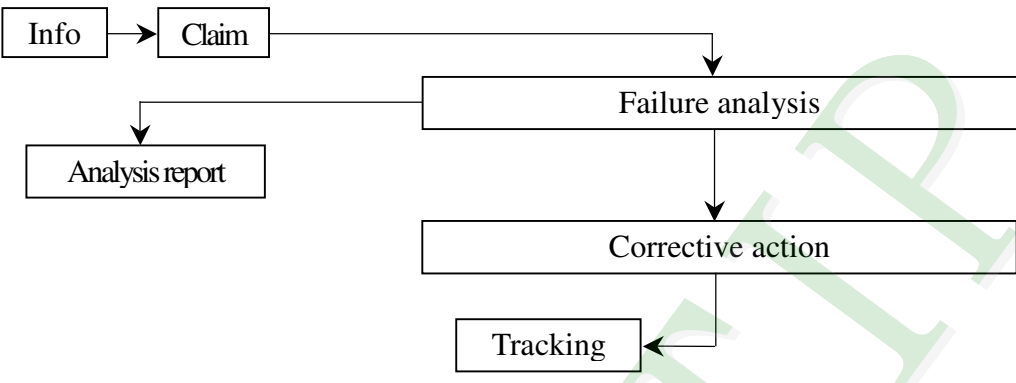
Item	Customer	Sales	R&D	Q.A	Manufacturing	Product control	Purchase	Inventory control
Sales Service	 <pre> graph TD     Info[Info] --&gt; Claim[Claim]     Claim --&gt; FA[Failure analysis]     Claim --&gt; AR[Analysis report]     FA --&gt; CA[Corrective action]     CA --&gt; Tracking[Tracking]           </pre>							
Q.A Activity	1. ISO 9001 Maintenance Activities 3. Equipment calibration 5. Standardization Management				2. Process improvement proposal 4. Education And Training Activities			

## 3.2 Inspection Specification

### 1. Inspection Specification

- ◆Scope : The document shall be applied to TFT-LCD Module for 3.5" ~10" (Ver. 02).
- ◆Inspection Standard : MIL-STD-105E Table Normal Inspection Single Sampling Level II.
- ◆Equipment : Gauge、MIL-STD、Powertip Tester、Sample
- ◆Defect Level : Major Defect AQL : 0.4 ; Minor Defect AQL : 1.5
- ◆OUT Going Defect Level : Sampling.
- ◆Standard of the product appearance test :

#### a. Manner of appearance test :

- (1). The test best be under 20W×2 fluorescent light , and distance of view must be at 30 cm.
- (2). The test direction is base on about around 45° of vertical line.

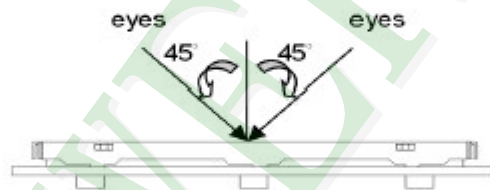

#### (3). Definition of area.

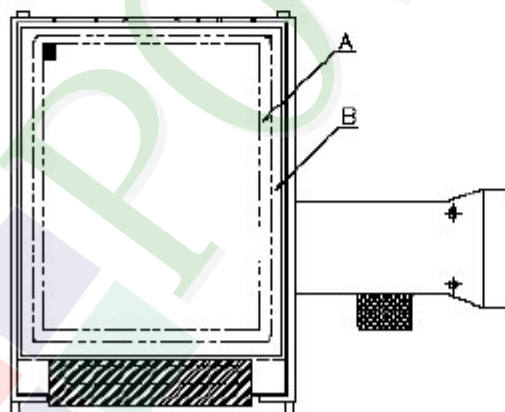

*A* area : viewing area

*B* area : Outside of viewing area

#### (4). Standard of inspection : (Unit : mm)

**◆Specification For TFT-LCD Module 3.5" ~10" :**

(Ver. 02)

NO	Item	Criterion	Level												
01	Product condition	1. 1 The part number is inconsistent with work order of production.	Major												
		1. 2 Mixed product types.	Major												
		1. 3 Assembled in inverse direction.	Major												
02	Quantity	2. 1 The quantity is inconsistent with work order of production.	Major												
03	Outline dimension	3. 1 Product dimension and structure must conform to structure diagram.	Major												
04	Electrical Testing	4. 1 Missing line character and icon.	Major												
		4. 2 No function or no display.	Major												
		4. 3 Display malfunction.	Major												
		4. 4 LCD viewing angle defect.	Major												
		4. 5 Current consumption exceeds product specifications.	Major												
05	Dot defect (Bright dot 、 Dark dot) On -display	<table border="1" style="margin-left: auto; margin-right: auto;"> <thead> <tr> <th colspan="2">Item</th> <th>Acceptance (Q'ty)</th> </tr> </thead> <tbody> <tr> <td rowspan="4" style="text-align: center;">Dot Defect</td> <td style="text-align: center;">Bright Dot</td> <td style="text-align: center;"><math>\leq 4</math></td> </tr> <tr> <td style="text-align: center;">Dark Dot</td> <td style="text-align: center;"><math>\leq 5</math></td> </tr> <tr> <td style="text-align: center;">Joint Dot</td> <td style="text-align: center;"><math>\leq 3</math></td> </tr> <tr> <td style="text-align: center;">Total</td> <td style="text-align: center;"><math>\leq 7</math></td> </tr> </tbody> </table>	Item		Acceptance (Q'ty)	Dot Defect	Bright Dot	$\leq 4$	Dark Dot	$\leq 5$	Joint Dot	$\leq 3$	Total	$\leq 7$	Minor
		Item		Acceptance (Q'ty)											
		Dot Defect	Bright Dot	$\leq 4$											
			Dark Dot	$\leq 5$											
			Joint Dot	$\leq 3$											
Total	$\leq 7$														
5. 1 Inspection pattern : full white , full black , Red , Green and blue screens.															
5. 2 It is defined as dot defect if defect area $> 1/2$ dot.															
5. 3 The distance between two dot defect $\geq 5$ mm.															

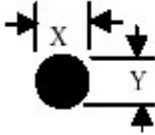
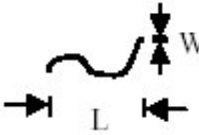
NO	Item	Criterion	Level																												
06	Black or white dot、scratch、contamination  Round type  $\Phi = (x + y) / 2$  Line type 	6. 1 Round type ( Non-display or display ) :  <table border="1" data-bbox="523 421 1252 788"> <thead> <tr> <th>Dimension (diameter : <math>\Phi</math>)</th> <th>Acceptance (Q'ty)</th> </tr> </thead> <tbody> <tr> <td><math>\Phi \leq 0.25</math></td> <td>Ignore</td> </tr> <tr> <td><math>0.25 &lt; \Phi \leq 0.50</math></td> <td>5</td> </tr> <tr> <td><math>\Phi &gt; 0.50</math></td> <td>0</td> </tr> <tr> <td>Total</td> <td>5</td> </tr> </tbody> </table>  6. 2 Line type( Non-display or display ) :  <table border="1" data-bbox="497 945 1279 1388"> <thead> <tr> <th>Length (L)</th> <th>Width (W)</th> <th>Acceptance (Q'ty)</th> </tr> </thead> <tbody> <tr> <td>---</td> <td><math>W \leq 0.03</math></td> <td>Ignore</td> </tr> <tr> <td><math>L \leq 10.0</math></td> <td><math>0.03 &lt; W \leq 0.05</math></td> <td>4</td> </tr> <tr> <td><math>L \leq 5.0</math></td> <td><math>0.05 &lt; W \leq 0.10</math></td> <td>2</td> </tr> <tr> <td>---</td> <td><math>W &gt; 0.10</math></td> <td>As round type</td> </tr> <tr> <td colspan="2">Total</td> <td>5</td> </tr> </tbody> </table>	Dimension (diameter : $\Phi$ )	Acceptance (Q'ty)	$\Phi \leq 0.25$	Ignore	$0.25 < \Phi \leq 0.50$	5	$\Phi > 0.50$	0	Total	5	Length (L)	Width (W)	Acceptance (Q'ty)	---	$W \leq 0.03$	Ignore	$L \leq 10.0$	$0.03 < W \leq 0.05$	4	$L \leq 5.0$	$0.05 < W \leq 0.10$	2	---	$W > 0.10$	As round type	Total		5	Minor
Dimension (diameter : $\Phi$ )	Acceptance (Q'ty)																														
$\Phi \leq 0.25$	Ignore																														
$0.25 < \Phi \leq 0.50$	5																														
$\Phi > 0.50$	0																														
Total	5																														
Length (L)	Width (W)	Acceptance (Q'ty)																													
---	$W \leq 0.03$	Ignore																													
$L \leq 10.0$	$0.03 < W \leq 0.05$	4																													
$L \leq 5.0$	$0.05 < W \leq 0.10$	2																													
---	$W > 0.10$	As round type																													
Total		5																													
07	Polarizer Bubble	<table border="1" data-bbox="491 1482 1289 1892"> <thead> <tr> <th>Dimension (diameter : <math>\Phi</math>)</th> <th>Acceptance (Q'ty)</th> </tr> </thead> <tbody> <tr> <td><math>\Phi \leq 0.25</math></td> <td>Ignore</td> </tr> <tr> <td><math>0.25 &lt; \Phi \leq 0.50</math></td> <td>4</td> </tr> <tr> <td><math>0.50 &lt; \Phi \leq 0.80</math></td> <td>1</td> </tr> <tr> <td><math>\Phi &gt; 0.80</math></td> <td>0</td> </tr> <tr> <td>Total</td> <td>5</td> </tr> </tbody> </table>	Dimension (diameter : $\Phi$ )	Acceptance (Q'ty)	$\Phi \leq 0.25$	Ignore	$0.25 < \Phi \leq 0.50$	4	$0.50 < \Phi \leq 0.80$	1	$\Phi > 0.80$	0	Total	5	Minor																
Dimension (diameter : $\Phi$ )	Acceptance (Q'ty)																														
$\Phi \leq 0.25$	Ignore																														
$0.25 < \Phi \leq 0.50$	4																														
$0.50 < \Phi \leq 0.80$	1																														
$\Phi > 0.80$	0																														
Total	5																														

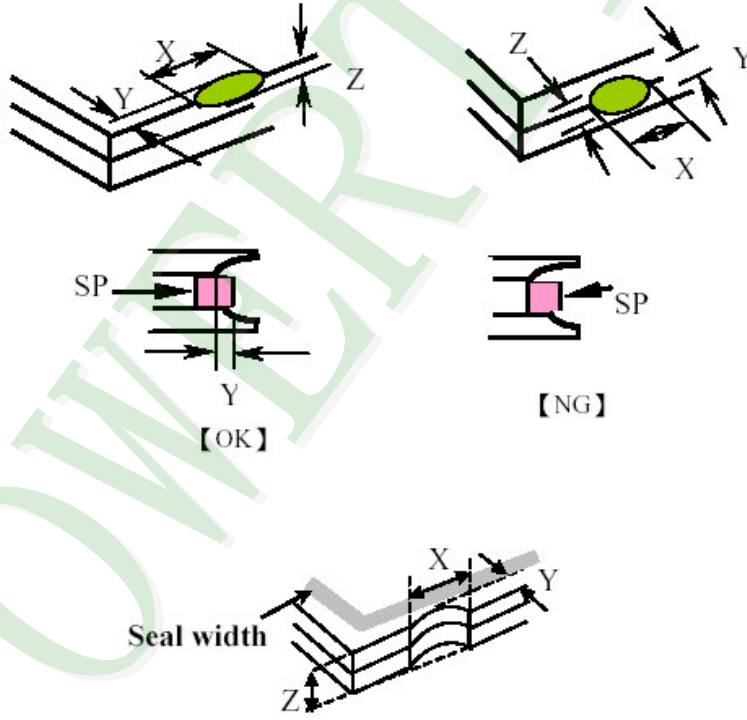
NO	Item	Criterion	Level						
08	The crack of glass	Symbols :  X : The length of crack Z : The thickness of crack t : The thickness of glass  Y : The width of crack. W : terminal length a : LCD side length	Minor						
		8.1 General glass chip : 8.1.1 Chip on panel surface and crack between panels:    <table border="1" data-bbox="542 1545 1340 1836"> <thead> <tr> <th>X</th> <th>Y</th> <th>Z</th> </tr> </thead> <tbody> <tr> <td><math>\leq a</math></td> <td>Crack can't enter viewing area</td> <td><math>\leq 1/2 t</math></td> </tr> <tr> <td><math>\leq a</math></td> <td>Crack can't exceed the half of SP width.</td> <td><math>1/2 t &lt; Z \leq 2 t</math></td> </tr> </tbody> </table>		X	Y	Z	$\leq a$	Crack can't enter viewing area	$\leq 1/2 t$
X	Y	Z							
$\leq a$	Crack can't enter viewing area	$\leq 1/2 t$							
$\leq a$	Crack can't exceed the half of SP width.	$1/2 t < Z \leq 2 t$							

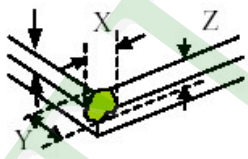
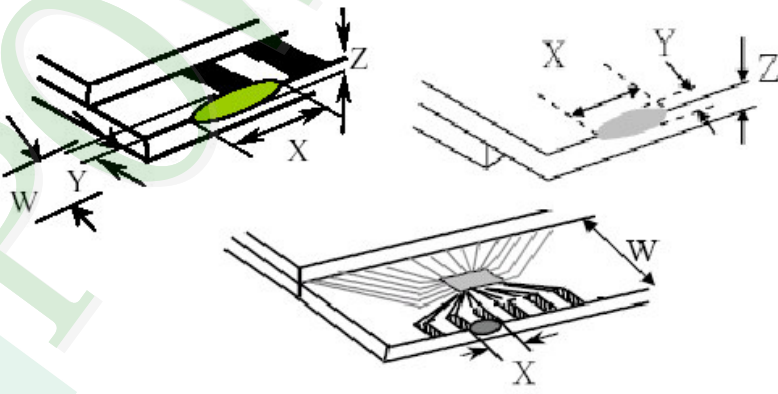
NO	Item	Criterion	Level										
08	The crack of glass	<p><b>Symbols :</b></p> <p><b>X :</b> The length of crack  <b>Z :</b> The thickness of crack  <b>t :</b> The thickness of glass</p> <p><b>Y :</b> The width of crack.  <b>W :</b> terminal length  <b>a :</b> LCD side length</p> <hr/> <p><b>8.1.2 Corner crack :</b></p>  <table border="1" data-bbox="529 779 1324 1064"> <thead> <tr> <th>X</th> <th>Y</th> <th>Z</th> </tr> </thead> <tbody> <tr> <td><math>\leq 1/5 a</math></td> <td>Crack can't enter viewing area</td> <td><math>Z \leq 1/2 t</math></td> </tr> <tr> <td><math>\leq 1/5 a</math></td> <td>Crack can't exceed the half of SP width.</td> <td><math>1/2 t &lt; Z \leq 2 t</math></td> </tr> </tbody> </table>	X	Y	Z	$\leq 1/5 a$	Crack can't enter viewing area	$Z \leq 1/2 t$	$\leq 1/5 a$	Crack can't exceed the half of SP width.	$1/2 t < Z \leq 2 t$	Minor	
		X	Y	Z									
$\leq 1/5 a$	Crack can't enter viewing area	$Z \leq 1/2 t$											
$\leq 1/5 a$	Crack can't exceed the half of SP width.	$1/2 t < Z \leq 2 t$											
<p><b>8.2 Protrusion over terminal :</b></p> <p><b>8.2.1 Chip on electrode pad :</b></p>  <table border="1" data-bbox="566 1639 1332 1809"> <thead> <tr> <th></th> <th>X</th> <th>Y</th> <th>Z</th> </tr> </thead> <tbody> <tr> <td><b>Front</b></td> <td><math>\leq a</math></td> <td><math>\leq 1/2 W</math></td> <td><math>\leq t</math></td> </tr> <tr> <td><b>Back</b></td> <td><math>\leq a</math></td> <td><math>\leq W</math></td> <td><math>\leq 1/2 t</math></td> </tr> </tbody> </table>		X	Y	Z	<b>Front</b>	$\leq a$	$\leq 1/2 W$	$\leq t$	<b>Back</b>	$\leq a$	$\leq W$	$\leq 1/2 t$	
	X	Y	Z										
<b>Front</b>	$\leq a$	$\leq 1/2 W$	$\leq t$										
<b>Back</b>	$\leq a$	$\leq W$	$\leq 1/2 t$										

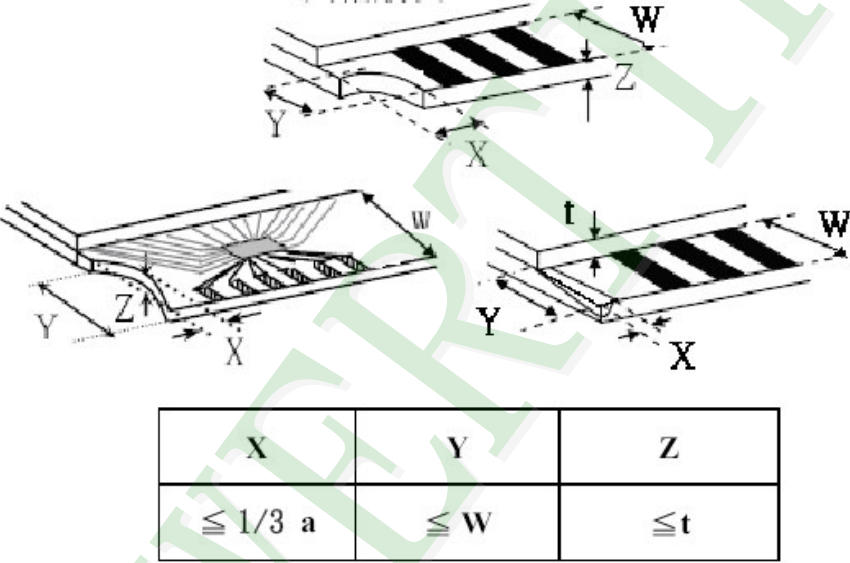
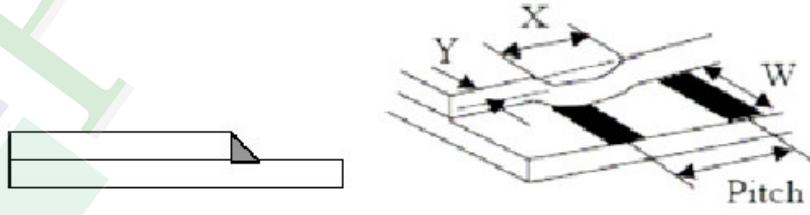
NO	Item	Criterion	Level			
08	The crack of glass	Symbols : X : The length of crack Y : The width of crack. Z : The thickness of crack W : terminal length t : The thickness of glass a : LCD side length	Minor			
		8.2.2 Non-conductive portion :  <p>⊙ If the chipped area touches the ITO terminal, over 2/3 of the ITO must remain and be inspected according to electrode terminal specifications.</p> 8.2.3 Glass remain :  <table border="1" data-bbox="550 1691 1236 1825"> <thead> <tr> <th>X</th> <th>Y</th> <th>Z</th> </tr> </thead> <tbody> <tr> <td><math>\leq a</math></td> <td><math>\leq 1/3 W</math></td> <td><math>\leq t</math></td> </tr> </tbody> </table>		X	Y	Z
X	Y	Z				
$\leq a$	$\leq 1/3 W$	$\leq t$				

**◆Specification For TFT-LCD Module 3.5" ~10" :**

(Ver. 02)

NO	Item	Criterion	Level
09	Backlight elements	9. 1 Backlight can't work normally.	Major
		9. 2 Backlight doesn't light or color is wrong.	Major
		9. 3 Illumination source flickers when lit.	Major
10	General appearance	10. 1 Pin type 、 quantity 、 dimension must match type in structure diagram.	Major
		10. 2 No short circuits in components on PCB or FPC .	Major
		10. 3 Parts on PCB or FPC must be the same as on the production characteristic chart .There should be no wrong parts , missing parts or excess parts.	Major
		10. 4 Product packaging must the same as specified on packaging specification sheet.	Minor
		10. 5 The folding and peeled off in polarizer are not acceptable.	Minor
		10. 6 The PCB or FPC between B/L assembled distance(PCB or FPC ) is $\leq 1.5$ mm.	Minor

## 4. RELIABILITY TEST

### 4.1 Reliability Test Condition

Ver.02

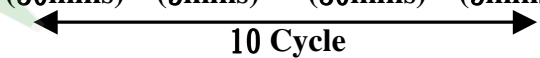
NO.	TEST ITEM	TEST CONDITION											
1	High Temperature Storage Test	Keep in <b>+80 ±2°C</b> 96 hrs Surrounding temperature, then storage at normal condition 4hrs.											
2	Low Temperature Storage Test	Keep in <b>-30 ±2°C</b> 96 hrs Surrounding temperature, then storage at normal condition 4hrs.											
3	High Temperature / High Humidity Storage Test	Keep in <b>+60°C / 90% R.H</b> duration for 96 hrs Surrounding temperature, then storage at normal condition 4hrs. (Excluding the polarizer)											
4	ESD Test	Air Discharge: Apply <b>2 KV</b> with 5 times Discharge for each polarity +/-	Contact Discharge: Apply <b>250 V</b> with 5 times discharge for each polarity +/-										
		1. Temperature ambience : <b>15°C ~ 35°C</b> 2. Humidity relative : <b>30% ~ 60%</b> 3. Energy Storage Capacitance(Cs+Cd) : <b>150pF±10%</b> 4. Discharge Resistance(Rd) : <b>330 Ω±10%</b> 5. Discharge, mode of operation : Single Discharge (time between successive discharges at least 1 sec) (Tolerance if the output voltage indication : <b>±5%</b> )											
5	Temperature Cycling Storage Test	<b>-20°C → +25°C → +70°C → +25°C</b> <b>(30mins) (5mins) (30mins) (5mins)</b>  Surrounding temperature, then storage at normal condition 4hrs.											
6	Vibration Test (Packaged)	1. Sine wave <b>10~55 Hz</b> frequency (1 min) 2. The amplitude of vibration : <b>1.5 mm</b> 3. Each direction (X、Y、Z) duration for <b>2 Hrs</b>											
7	Drop Test (Packaged)	<table border="1"> <thead> <tr> <th>Packing Weight (Kg)</th> <th>Drop Height (cm)</th> </tr> </thead> <tbody> <tr> <td>0 ~ 45.4</td> <td>122</td> </tr> <tr> <td>45.4 ~ 90.8</td> <td>76</td> </tr> <tr> <td>90.8 ~ 454</td> <td>61</td> </tr> <tr> <td>Over 454</td> <td>46</td> </tr> </tbody> </table> Drop direction : ※1 corner / 3 edges / 6 sides each 1times		Packing Weight (Kg)	Drop Height (cm)	0 ~ 45.4	122	45.4 ~ 90.8	76	90.8 ~ 454	61	Over 454	46
Packing Weight (Kg)	Drop Height (cm)												
0 ~ 45.4	122												
45.4 ~ 90.8	76												
90.8 ~ 454	61												
Over 454	46												

## 5. PRECAUTION RELATING PRODUCT HANDLING

### 5.1 SAFETY

- 5.1.1 If the LCD panel breaks , be careful not to get the liquid crystal to touch your skin.
- 5.1.2 If the liquid crystal touches your skin or clothes , please wash it off immediately by using soap and water.

### 5.2 HANDLING

- 5.2.1 Avoid any strong mechanical shock which can break the glass.
- 5.2.2 Avoid static electricity which can damage the CMOS LSI—When working with the module , be sure to ground your body and any electrical equipment you may be using.
- 5.2.3 Do not remove the panel or frame from the module.
- 5.2.4 The polarizing plate of the display is very fragile. So , please handle it very carefully ,do not touch , push or rub the exposed polarizing with anything harder than an HB pencil lead (glass , tweezers , etc.)
- 5.2.5 Do not wipe the polarizing plate with a dry cloth , as it may easily scratch the surface of plate.
- 5.2.6 Do not touch the display area with bare hands , this will stain the display area.
- 5.2.7 Do not use ketonics solvent & aromatic solvent. Use with a soft cloth soaked with a cleaning naphtha solvent.
- 5.2.8 To control temperature and time of soldering is  $320\pm 10^{\circ}\text{C}$  and 3-5 sec.
- 5.2.9 To avoid liquid (include organic solvent) stained on LCM .

### 5.3 STORAGE

- 5.3.1 Store the panel or module in a dark place where the temperature is  $25^{\circ}\text{C} \pm 5^{\circ}\text{C}$  and the humidity is below 65% RH.
- 5.3.2 Do not place the module near organics solvents or corrosive gases.
- 5.3.3 Do not crush , shake , or jolt the module.

### 5.4 TERMS OF WARRANTY

- 5.4.1 Applicable warrant period  
The period is within thirteen months since the date of shipping out under normal using and storage conditions.
- 5.4.2 Unaccepted responsibility  
This product has been manufactured to your company's specification as a part for use in your company's general electronic products. It is guaranteed to perform according to delivery specifications. For any other use apart from general electronic equipment , we cannot take responsibility if the product is used in nuclear power control equipment , aerospace equipment , fire and security systems or any other applications in which there is a direct risk to human life and where extremely high levels of reliability are required.



Approve	Check	Contact
Oliver	Stone	Mag

Documents NO.	PKG-PH320240T-006-IP1Q
---------------	------------------------

### 1. 包裝材料規格表 (Packaging Material) : (per carton)

No.	Item	Model	Dimensions (mm)	1Pcs Weight	Quantity	Total Weight
1	成品 (LCM)	PH320240T-006-IP1Q	76.9 X 63.9	0.0405	252	10.206
2	多層薄膜(1)POF	OTFILM0BA03ABA	19"X350X0.015	—	6	—
3	TRAY 盤 (2)Tray	TYPH32024004BA	352 X 260 X 12.8	0.0999	48	4.7952
4	內盒(3)Product Box	BX36627063ABBA	393 X 274 X 68	0.2692	6	1.6152
5	保利龍板(4)Polylon board	OTPLB00PL08ABA	550 X 393 X 20	0.0284	2	0.0568
6	外紙箱(5)Carton	BX57041027CCBA	570 X 410 X 265	1.4208	1	1.4208
7						
8						
9						

2. 一整箱總重量 (Total LCD Weight in carton) : 18.09 Kg±10%

3. 單箱數量規格表 (Packaging Specifications and Quantity) :

(1) LCM quantity per box : no per tray	6	x no of tray	7	=	42
(2) Total LCM quantity in carton : quantity per box	42	x no of boxes	6	=	252

Use empty tray  
空盤

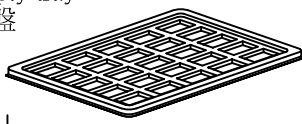

Put products into the tray

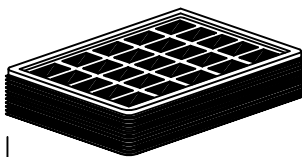

Tray stacking

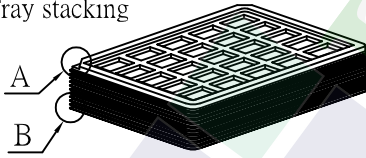

(1) 多層薄膜  
POF

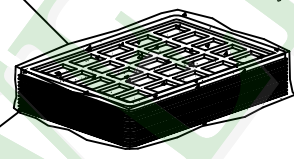

(2) TRAY 盤  
Tray

(4) 保利龍板  
Polylon board

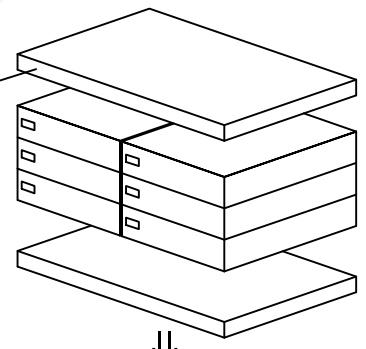

(3) 內盒  
Product Box

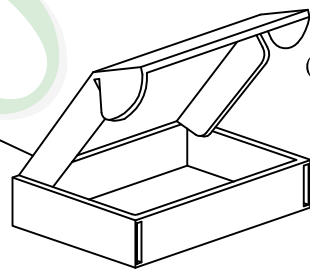

(5) 外紙箱  
Carton

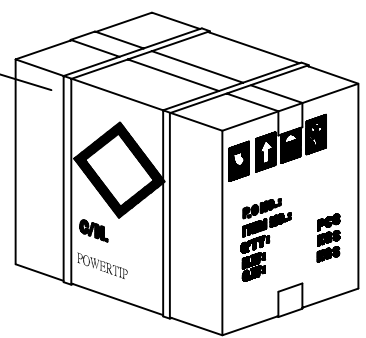

### 特 記 事 項 (REMARK)

#### 1. Label Specifications :

MODEL:
LOT NO:
QUANTITY:
CHECK:

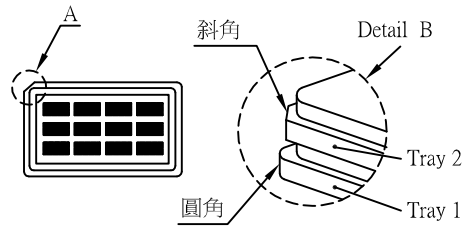

2. TRAY盤相疊時,需旋轉180度,請詳見B視圖  
Rotate tray 180 degrees and place on top of stack.  
Check the tray stack using Fig. B.

3. 可適用於單品包裝  
It's also suitable to Panel

4. Tray料號:  
Tray Number:PT-PH320240T-004-1