

Contents

1. SPECIFICATIONS

- 1.1 Features
- 1.2 Mechanical Specifications
- 1.3 Absolute Maximum Ratings
- 1.4 DC Electrical Characteristics
- 1.5 Optical Characteristics
- 1.6 Backlight & LED Characteristics
- 1.7 Touch Panel Characteristics

2. MODULE STRUCTURE

- 2.1 Counter Drawing
- 2.2 Interface Pin Description
- 2.3 Timing Characteristics
- 2.4 Power Sequence
- 2.5 Jumper

3. QUALITY ASSURANCE SYSTEM

- 3.1 Quality Assurance Flow Chart
- 3.2 Inspection Specification

4. RELIABILITY TEST

- 4.1 Reliability Test Condition

5. PRECAUTION RELATING PRODUCT HANDLING

- 5.1 Safety
- 5.2 Handling
- 5.3 Storage
- 5.4 Terms of Warranty

Appendix : LCM Drawing
Packaging

1. SPECIFICATIONS

1.1 Features

Main LCD Panel

Item	Standard Value
Display Type	320(R、G、B) * 240 Dots
LCD Type	Normally white , Transmissive type
Screen size(inch)	3.5 inch
Viewing Direction	6 O'clock
Color configuration	RGB-Strip
Backlight	LED B/L
Interface	8-bits serial RGB interface
Driver IC	Himax: HX8238-A
ROHS	THIS PRODUCT CONFORMS THE ROHS OF PTC Detail information please refer web side : http://www.powertip.com.tw/news/LatestNews.asp

1.2 Mechanical Specifications

Item	Standard Value	Unit
Outline Dimension	76.9 (W) * 63.9(L) * 9.75 (H)(Max)	mm

LCD Panel

Item	Standard Value	Unit
Active Area	70.08 (W) * 52.56 (L)	mm

Touch Panel

Item	Standard Value	Unit
Viewing Area (T/P)	72.00 (W) * 54.56 (L)	mm
Active Area (T/P)	70.80 (W) * 53.26 (L)	mm

Note : For detailed information please refer to LCM drawing

1.3 Absolute Maximum Ratings

Module

Item	Symbol	Condition	Min.	Max.	Unit
System Power Supply Voltage	VDDIO	VSS	-0.3	+4.0	V
Input Voltage	V _i	-	-0.3	5.0	V
Operating Temperature	T _{OP}	-	-20	+70	°C
Storage Temperature	T _{ST}	-	-30	+80	°C
Storage Humidity	H _D	T _a < 40 °C	20	90	%RH

1.4 DC Electrical Characteristics

Module

GND = 0V, T_a = 25°C

Item	Symbol	Condition	Min.	Typ.	Max.	Unit
Power Supply Voltage	VDDIO	-	-	3.3	-	V
V _{COM} High Voltage	V _{COMH}	-	2.5	(3.6)	4.5	V
V _{COM} Low Voltage	V _{COML}	-	-3	(-2.4)	0	V
Input High Voltage	V _{IH1}	-	0.8* VDDIO	-	VDDIO	V
Input Low Voltage	V _{IL1}	-	0	-	0.2* VDDIO	V
Output High Voltage	V _{OH1}	I _{OH} =-0.1mA	0.9 * VDDIO	-	VDD	V
Output Low Voltage	V _{OL1}	I _{OL} =0.1mA	0	-	0.1* VDDIO	V
Supply Current	IDDIO	VDDIO =3.3 V Pattern=full display*1	-	200	300	mA

Note1:Maximum current display

1.5 Optical Characteristics

TFT LCD Panel

VDDIO =3.3V, Ta=25°C

Item	Symbol	Condition	Min.	Typ.	Max.	unit		
Response time	Tr + Tf	Ta = 25°C θX, θY = 0°	-	35	53	ms	Note2	
Viewing angle	Top	θY+	CR ≥ 10	-	45	-	Deg.	Note4
	Bottom	θY-		-	50	-		
	Left	θX-		-	50	-		
	Right	θX+		-	50	-		
Contrast ratio	CR		200	250	-	-	Note3	
Color of CIE Coordinate (With B/L& T/P)	White	X	Ta = 25°C θX , θY = 0°	0.27	0.32	0.37	-	Note1
		Y		0.31	0.36	0.41		
	Red	X		0.55	0.60	0.65		
		Y		0.30	0.35	0.40		
	Green	X		0.28	0.33	0.38		
		Y		0.55	0.60	0.65		
	Blue	X		0.09	0.14	0.19		
		Y		0.05	0.10	0.15		
Average Brightness Pattern=white display (With B/L & T/P)	IV	IF= 20mA	110	130	-	cd/m ²	Note1	
Uniformity (With B/L & T/P)	B	IF= 20mA	70	-	-	%	Note1	

Note1:

1 : $B = B(\min) / B(\max) \times 100\%$

2 : Measurement Condition for Optical Characteristics:

a : Environment: 25 ±5 / 60±20%R.H , no wind , dark room below 10 Lux at typical lamp current and typical operating frequency.

b : Measurement Distance: 500 ± 50 mm , (θ= 0°)

c : Equipment: TOPCON BM-7 fast , (field 1°) , after 10 minutes operation.

d : The uncertainty of the C.I.E coordinate measurement ±0.01 , Average Brightness ± 4%

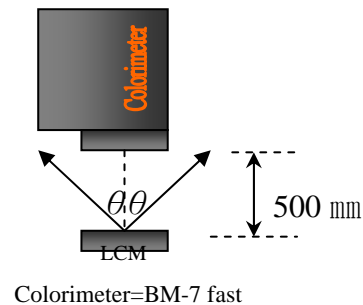

Note2: Definition of response time:

The output signals of photo detector are measured when the input signals are changed from "black" to "white"(falling time) and from "white" to "black"(rising time), respectively. The response time is defined as the time interval between the 10% and 90% of Amplitudes.

Refer to figure as below:

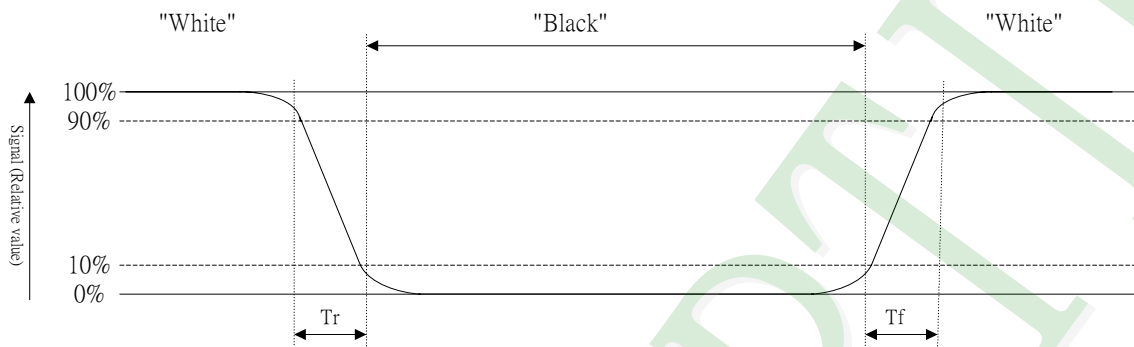

Note3: Definition of contrast ratio:

Contrast ratio is calculated with the following formula

$$\text{Contrast ratio (CR)} = \frac{\text{Photo detector output when LCD is at "White" state}}{\text{Photo detector output when LCD is at "Black" state}}$$

Note4: Definition of viewing angle:

Refer to figure as below:

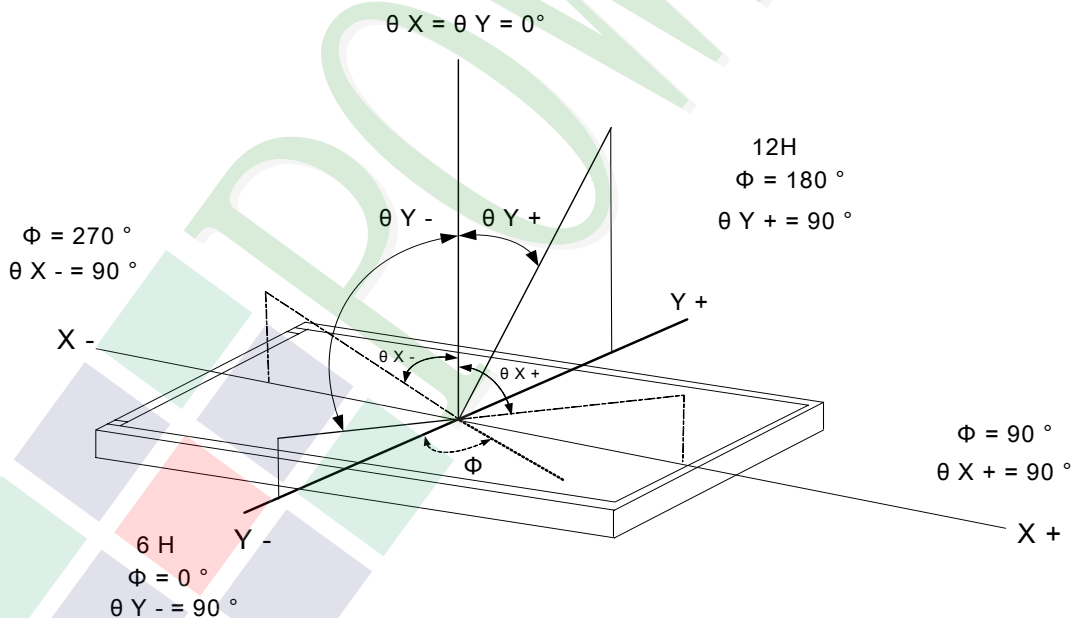

1.6 Backlight & LED Characteristics

LCD Module with LED Backlight

Maximum Ratings

Item	Symbol	Conditions	Min.	Max.	Unit
Forward Voltage	VF	Ta =25°C	-	24	V
Forward Current	IF	Ta =25°C	-	30	mA
Reverse Voltage	VR	Ta =25°C	-	30	V
Power Dissipation	PD	Ta =25°C	-	720	mW

Electrical / Optical Characteristics

Item	Symbol	Conditions	Min.	Typ.	Max.	Unit
Forward Voltage	VF	IF= 20mA	-	19.8	21	V
Average Brightness	IV		3500	4300	--	cd/m ²
Color of CIE Coordinate	X		--	0.29	--	-
	Y		--	0.29	--	
Color	White					

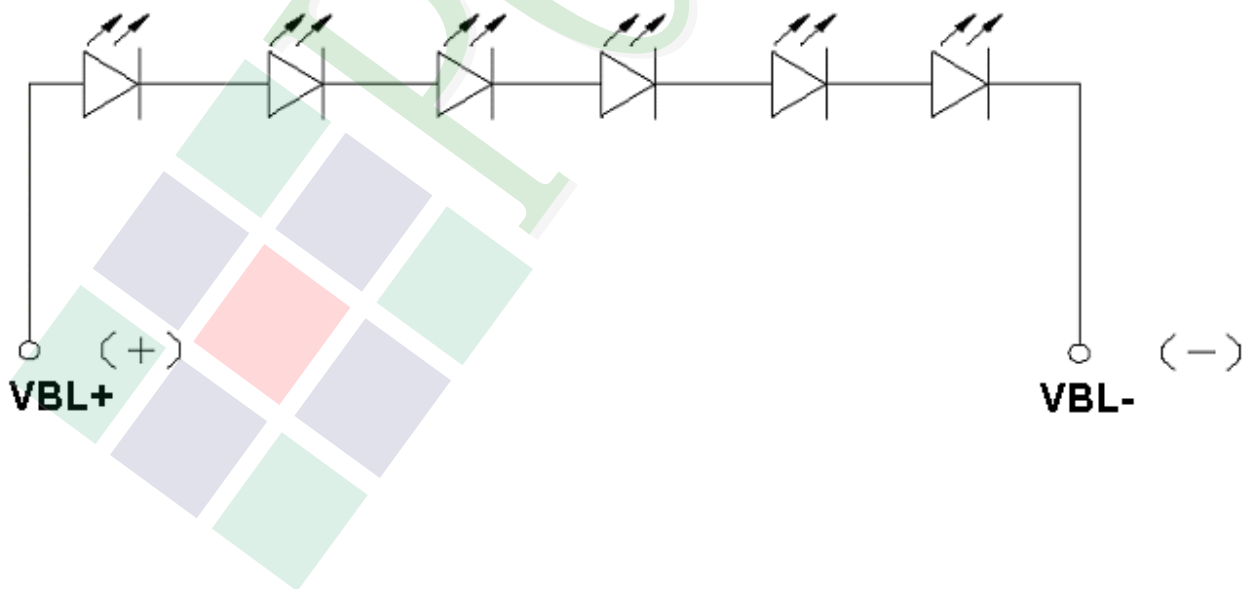

1.7 Touch Panel Characteristics

1.7.1 Touch Panel General Standard Specification

Item	Specification
Input Method	Finger or stylus pen
Operating Temperature Range	-20°C~70°C ,20~90%RH
Storage Temperature Range	-30 ~80 ,10~90%RH
Surface Hardness	3H- pressure 150gf , 45deg.
Hitting Durability	1,000,000 times min. (Tip R 8 mm)
Pen Sliding Durability	100,000 times min. (Tip R0.8mm)
Insulation Impedance	DC25V 10MΩ ↑
Light Transparency	80%min.
Linearity	±1.5%(initial value) ,± 3.0%(after environmental and life test)
Minimum input Force	Max : 80gf

1.7.2 Touch Panel Electrical Characteristics

- (A) Insulation Resistance.
10 M Ω or more (DC 25 V)
- (B) Resistance Between Terminals.
Direction X (Film side): 300 Ω ~900 Ω
Direction Y (Glass side): 200 Ω ~800 Ω
- (C) Linearity.
 $\pm 1.5\%$ (initial value) , $\pm 3.0\%$ (after environmental and life test)
- (D) Operating Voltage..
Max Voltage: 7V DC

2. MODULE STRUCTURE

2.1 Counter Drawing

2.1.1 LCM Mechanical Diagram

* See Appendix

2.1.2 Block Diagram

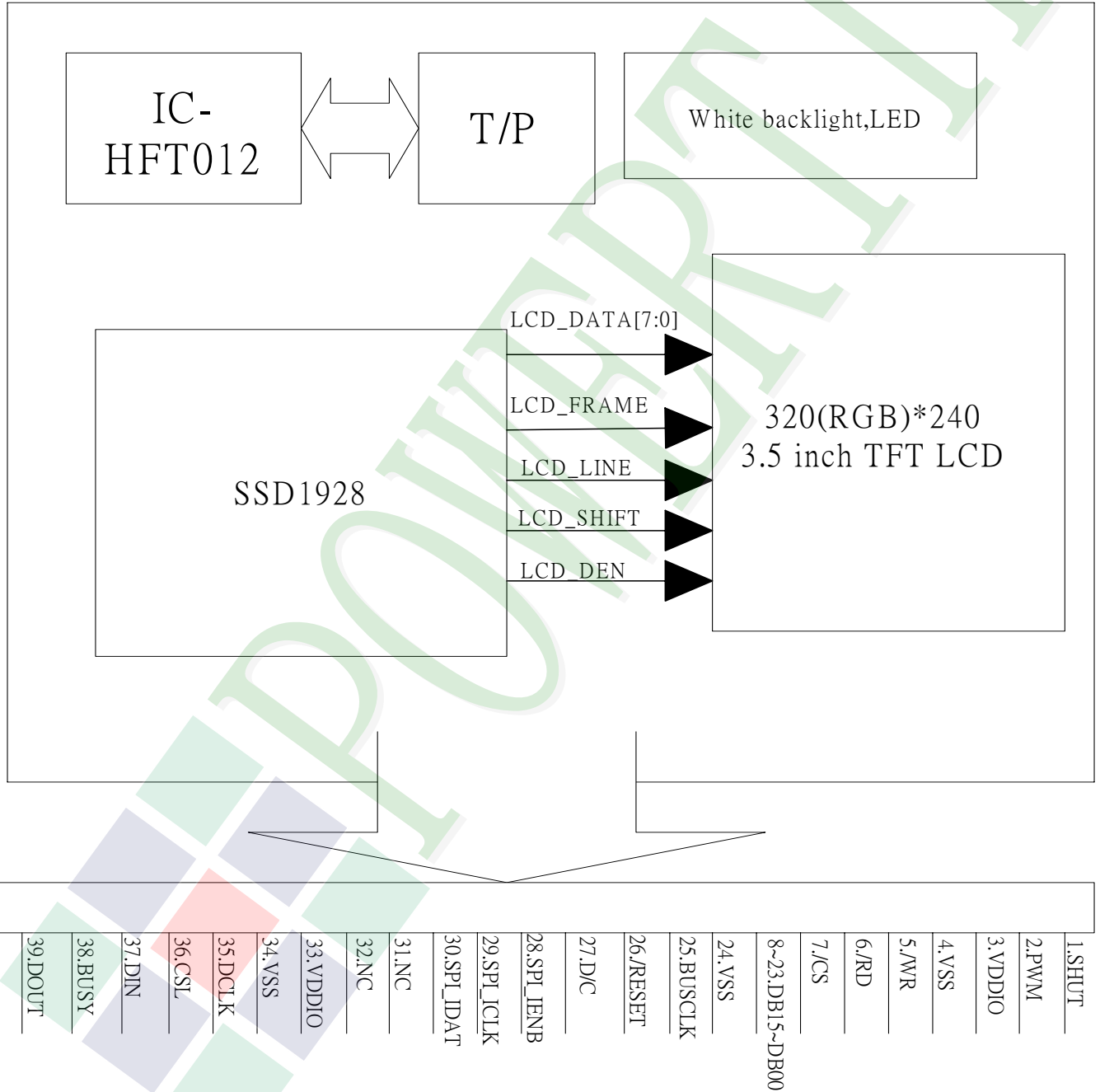

2.2 Interface Pin Description

Pin No	Symbol	Function
1	SHUT	Display shut down pin to put the driver into sleep mode. A sharp falling edge must be provided to such pin when IC power on. Internal pull low. - Connect to VDDIO for sleep mode - Connect to VSS for normal operating mode (Refer to Power Up Sequence)
2	PWM	B/L PWM.
3	VDDIO	Power Supply Voltage.
4	VSS	Ground.
5	/WR	For 8080, this is an input of write enable signal.
6	/RD	For 8080, this is an input of read enable signal.
7	/CS	Chip select input.
8	DB15	Data bus.
9	DB14	Data bus.
10	DB13	Data bus.
11	DB12	Data bus.
12	DB11	Data bus.
13	DB10	Data bus.
14	DB09	Data bus.
15	DB08	Data bus.
16	DB07	Data bus.
17	DB06	Data bus.
18	DB05	Data bus.
19	DB04	Data bus.
20	DB03	Data bus.
21	DB02	Data bus.
22	DB01	Data bus.

Pin No	Symbol	Function
23	DB00	Data bus.
24	VSS	Ground.
25	BUSCLK	Clock source input.
26	/RESET	Reset.
27	D/C	For 8080, this pin is used as data / command select.
28	SPI_IENB	Serial port data enable signal.
29	SPI_ICLK	Serial data clock.
30	SPI_IDAT	Serial data.
31	NC	Not Connect
32	NC	Not Connect
33	VDDIO	Power Supply Voltage. (For T/P)
34	VSS	Ground. (For T/P)
35	DCLK	Serial Interface Clock Input. (For T/P)
36	CSL	Chip Select Input (Active Low); this pin is used to initialize the transmission and ADC conversion, don't tied to GND directly. (For T/P)
37	DIN	Serial Data Input. (For T/P)
38	BUSY	Busy Output. High impedance when CSL is high. (For T/P)
39	DOUT	Serial Data output. High impedance when CSL is high. (For T/P)
40	PENIRQ	Pen Interrupt. (For T/P)

2.3 Timing Characteristics

2.3.1 SPI Read

First Transmission (Register)

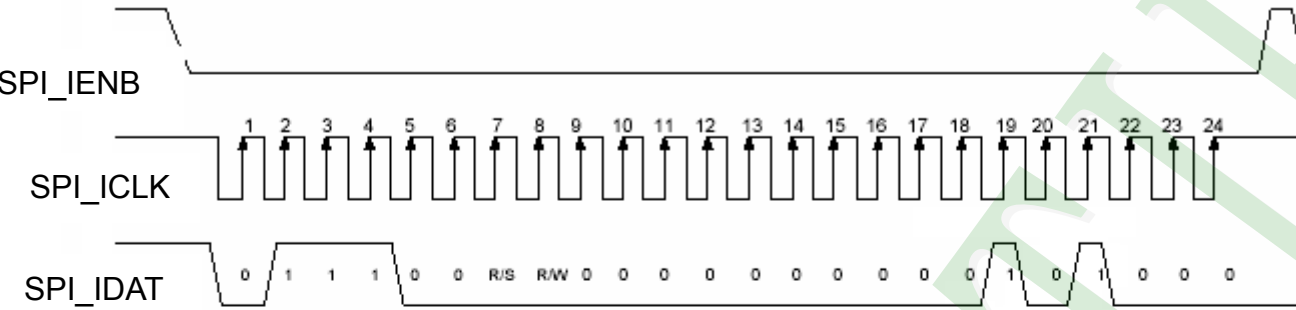

Second Transmission (Data)

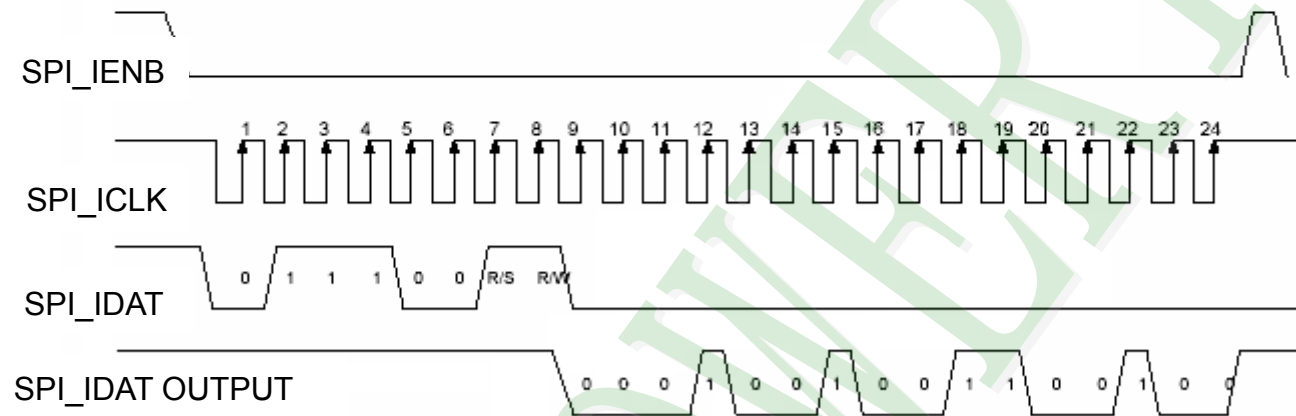

Note: The example Read "0x1264h" from register R28h.

SPI interface Timing Diagram & Read SPI Example

2.3.2 SPI Write

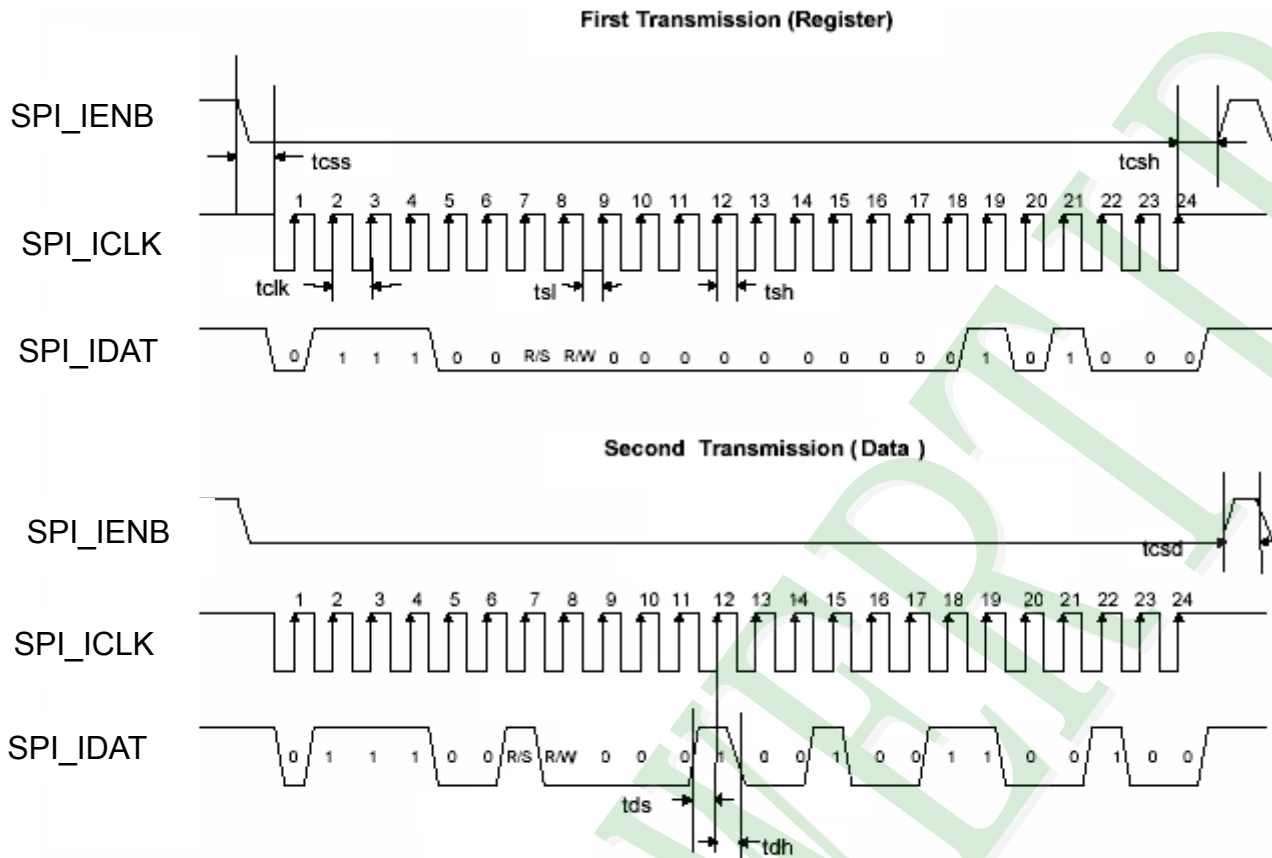

Note: The example writes "0x1264h" to register R28h.
SPID connected to VSS.

SPI interface Timing Diagram & Write SPI Example

2.3.3 SPI Timing Table

Characteristics	Symbol	Min.	Typ.	Max.	Unit
Serial Clock Frequency	fclk	-	-	20	MHz
Serial Clock Cycle Time	clk	50	-	-	ns
Clock Low Width	tsl	25	-	-	ns
Clock High Width	tsh	25	-	-	ns
Clock Rising Time	trs	-	-	30	ns
Clock Falling Time	tfl	-	-	30	ns
Chip Select Setup Time	tcss	0	-	-	ns
Chip Select Hold Time	tcsh	10	-	-	ns
Chip Select High Delay Time	tcsd	20	-	-	ns
Data Setup Time	tds	5	-	-	ns
Data Hold Time	tdh	10	-	-	ns

SPI Timing

2.4 Power Sequence

2.4.1 Power up sequence

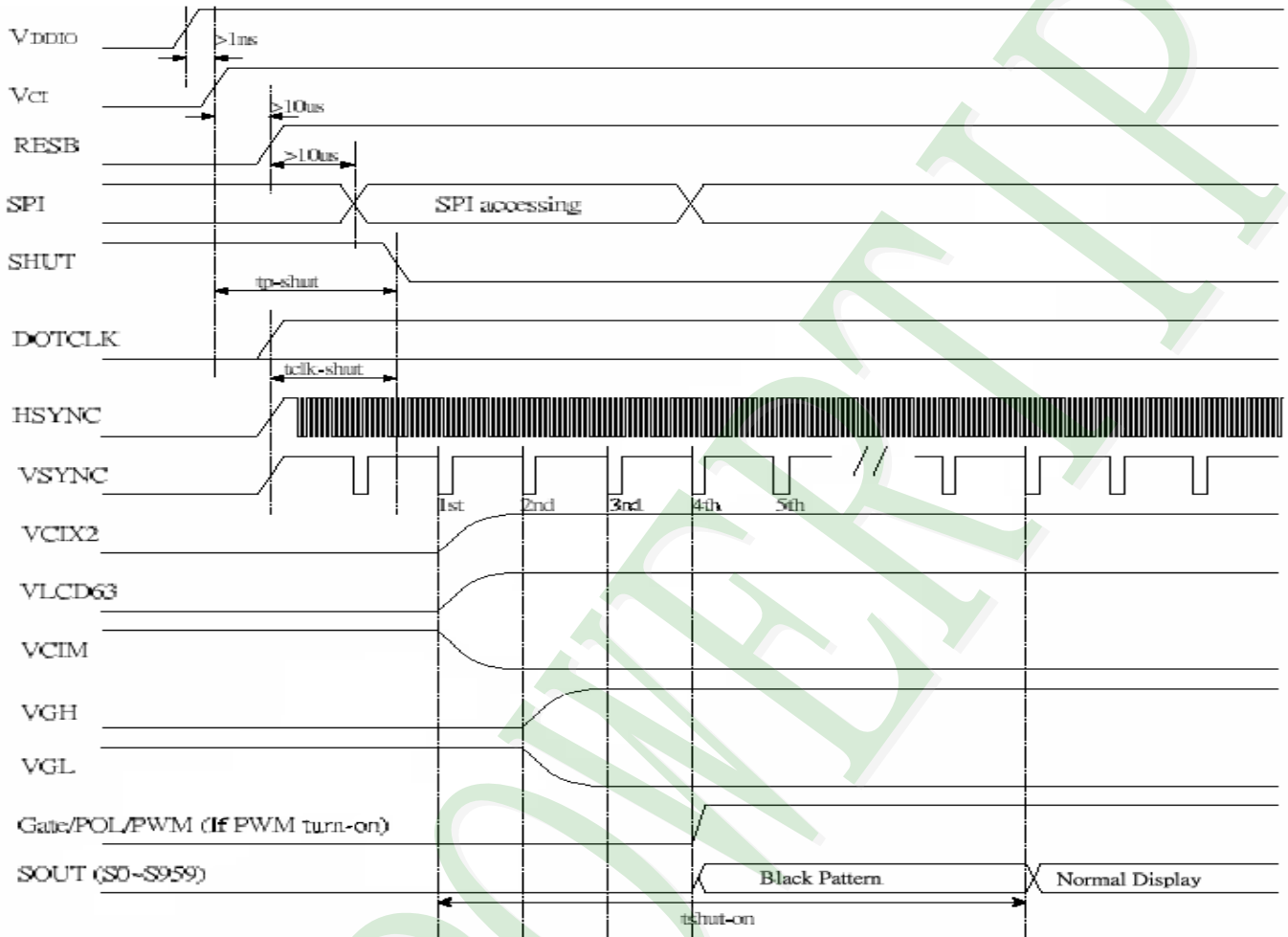

Characteristics	Symbol	Min.	Typ.	Max.	Unit
VCI/ VDDIO on to falling edge of SHUT	tp-shut	1	-	-	us
DOTCLK to falling edge of SHUT	tclk-shut (Note1)	1	-	-	clk
Falling edge of SHUT to display start - 1 line: 408 clk - 1 frame: 262 line - DOTCLK = 6.5MHz	tshut-on (Note2)	-	10	-	frame

Power Up Sequence

Note1: It is necessary to input DOTCLK before the falling edge of SHUT.

Note2: Display starts at 10th falling edge of VSTNC after the falling edge of SHUT. The display starts at the falling edge of VSYNC which is determined by BLT[1:0] of R04h.

Note : The voltage of VDD be boost from VDDIO.

2.4.2 Power down sequence

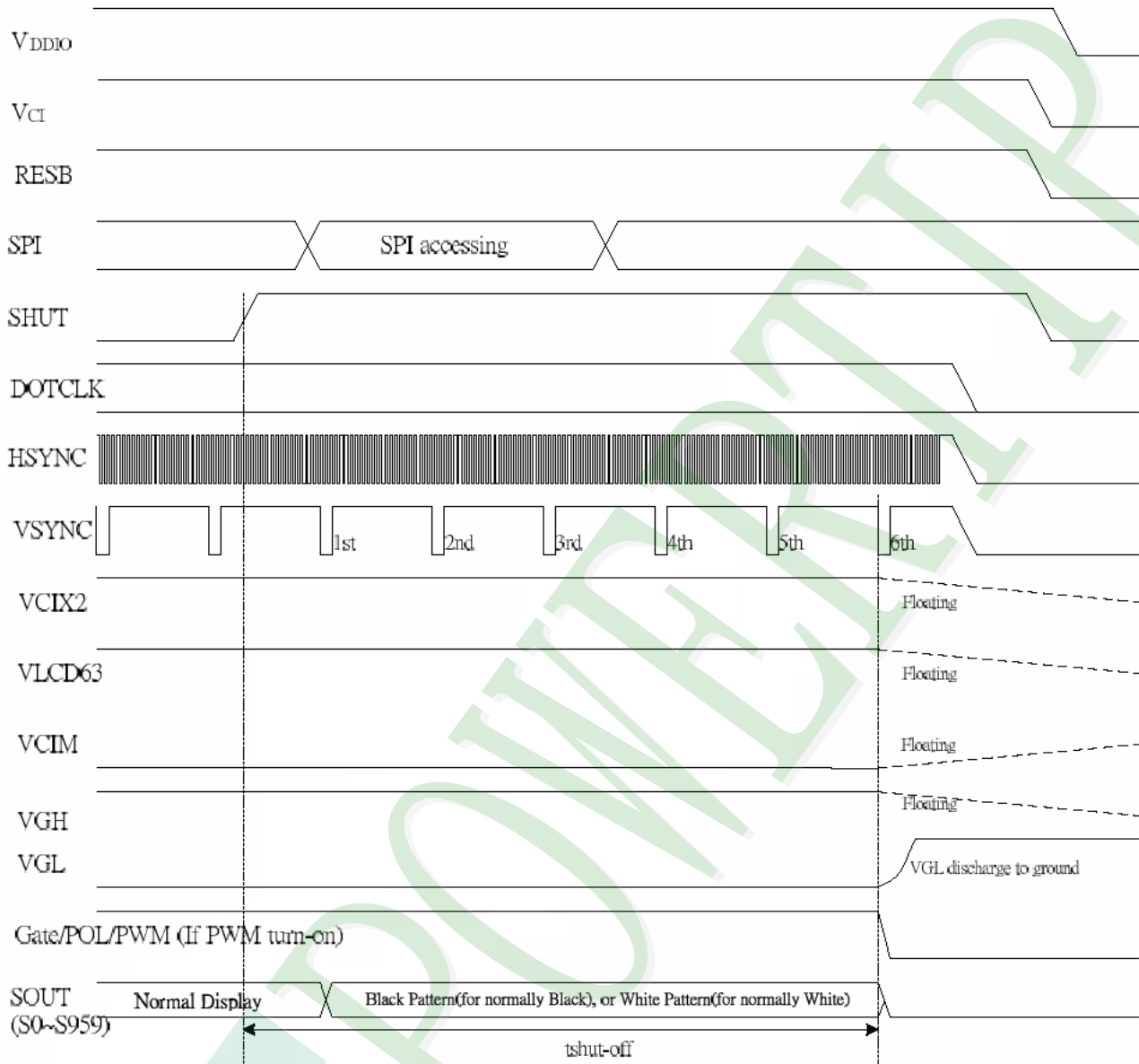

Characteristics	Symbol	Min.	Typ.	Max.	Unit
Rising edge of SHUT to display off - 1 line: 408 clk - 1 frame: 262 line - DOTCLK = 6.5MHz	tshut-off	-	-	6	frame

Note: DOTCLK must be maintained at least 6 frames after the rising edge of SHUT.
Display become off at the 6nd falling edge of VSTNC after the falling edge of SHUT.
If RESET signal is necessary for power down, provide it after the 6-frames-cycle of the SHUT period.

Power Down Sequence

Note : The voltage of VDD be boost from VDDIO.

2.5 JUMPER(Setting different use)

(J1-1,J2-1,J3-1)



3. QUALITY ASSURANCE SYSTEM

3.1 Quality Assurance Flow Chart

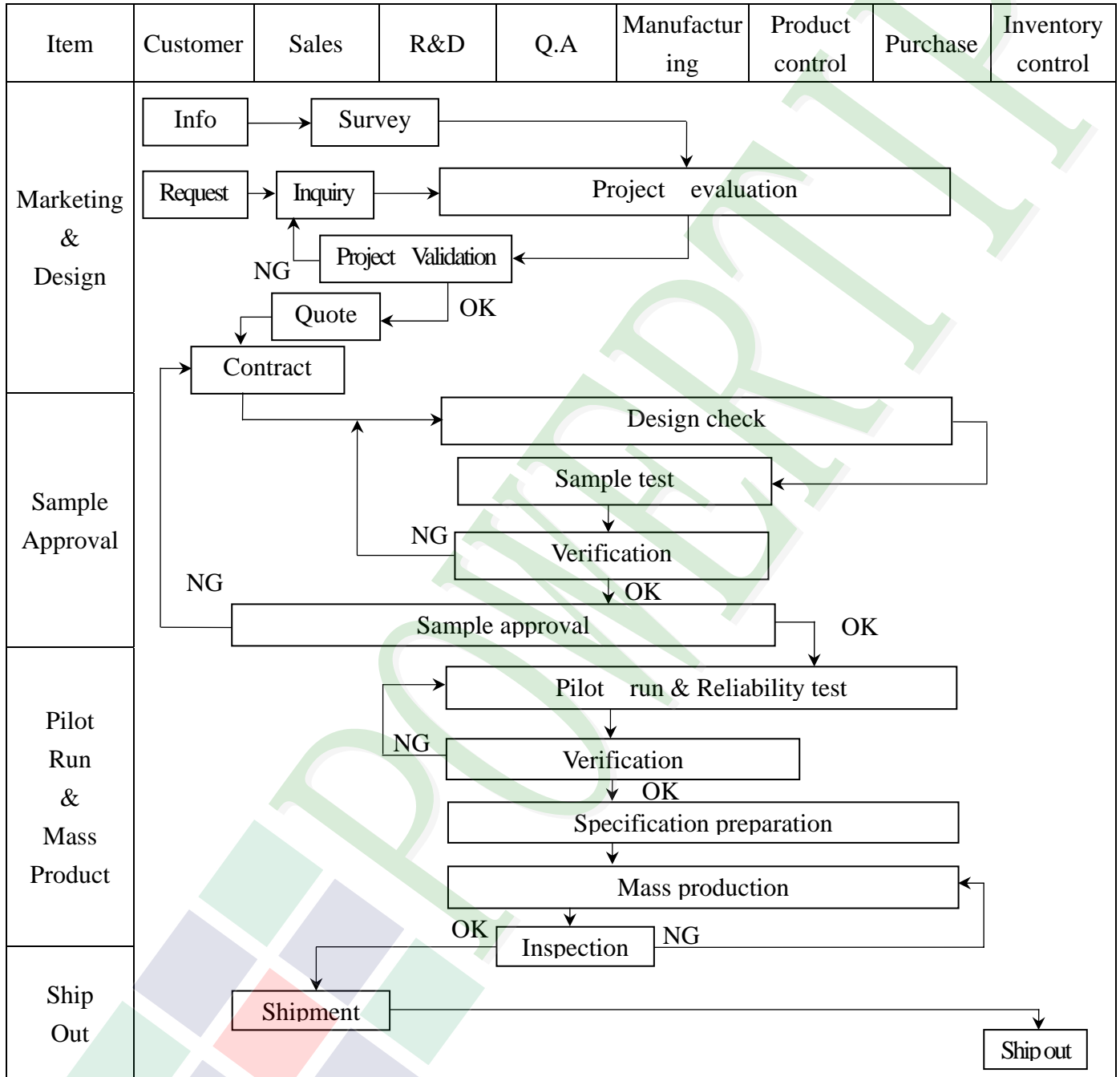

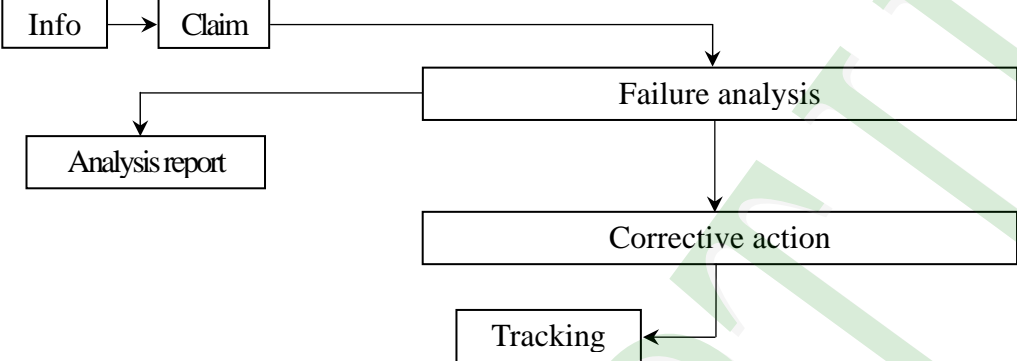
Item	Customer	Sales	R&D	Q.A	Manufacturing	Product control	Purchase	Inventory control
Sales Service	 <pre> graph TD Info[Info] --> Claim[Claim] Claim --> Failure[Failure analysis] Claim --> Report[Analysis report] Failure --> Action[Corrective action] Action --> Tracking[Tracking] </pre>							
Q.A Activity	1. ISO 9001 Maintenance Activities 3. Equipment calibration 5. Standardization Management				2. Process improvement proposal 4. Education And Training Activities			

3.2 Inspection Specification

1. Inspection Specification

- ◆Scope : The document shall be applied to TFT-LCD Module for 3.5" ~10" (Ver. 02).
- ◆Inspection Standard : MIL-STD-105E Table Normal Inspection Single Sampling Level II.
- ◆Equipment : Gauge 、 MIL-STD 、 Powertip Tester 、 Sample
- ◆Defect Level : Major Defect AQL : 0.4 ; Minor Defect AQL : 1.5
- ◆OUT Going Defect Level : Sampling.
- ◆Standard of the product appearance test :

a. Manner of appearance test :

- (1). The test best be under 20W×2 fluorescent light , and distance of view must be at 30 cm.
- (2). The test direction is base on about around 45° of vertical line.

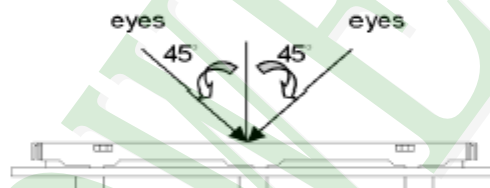

(3). Definition of area.

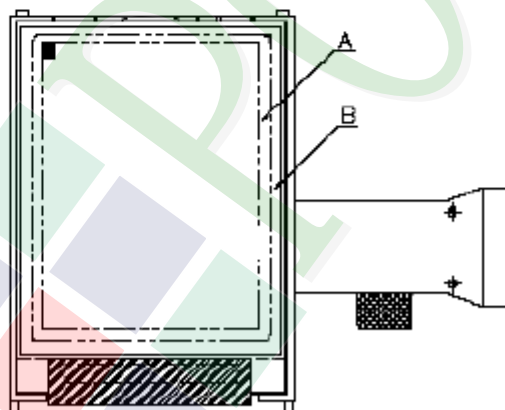

A area : viewing area



B area : Outside of viewing area

(4). Standard of inspection : (Unit : mm)

◆ Specification For TFT-LCD Module 3.5" ~10" :

(Ver. 02)

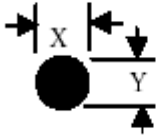
NO	Item	Criterion	Level										
01	Product condition	1. 1 The part number is inconsistent with work order of production.	Major										
		1. 2 Mixed product types.	Major										
		1. 3 Assembled in inverse direction.	Major										
02	Quantity	2. 1 The quantity is inconsistent with work order of production.	Major										
03	Outline dimension	3. 1 Product dimension and structure must conform to structure diagram.	Major										
04	Electrical Testing	4. 1 Missing line character and icon.	Major										
		4. 2 No function or no display.	Major										
		4. 3 Display malfunction.	Major										
		4. 4 LCD viewing angle defect.	Major										
		4. 5 Current consumption exceeds product specifications.	Major										
05	Dot defect (Bright dot , Dark dot) On -display	<table border="1" style="margin-left: auto; margin-right: auto;"> <thead> <tr> <th>Item</th> <th>Acceptance (Q'ty)</th> </tr> </thead> <tbody> <tr> <td>Bright Dot</td> <td>≤ 4</td> </tr> <tr> <td>Dark Dot</td> <td>≤ 5</td> </tr> <tr> <td>Joint Dot</td> <td>≤ 3</td> </tr> <tr> <td>Total</td> <td>≤ 7</td> </tr> </tbody> </table>	Item	Acceptance (Q'ty)	Bright Dot	≤ 4	Dark Dot	≤ 5	Joint Dot	≤ 3	Total	≤ 7	Minor
		Item	Acceptance (Q'ty)										
		Bright Dot	≤ 4										
		Dark Dot	≤ 5										
		Joint Dot	≤ 3										
Total	≤ 7												
5. 1 Inspection pattern : full white , full black , Red , Green and blue screens.													
5. 2 It is defined as dot defect if defect area $> 1/2$ dot.													
5. 3 The distance between two dot defect ≥ 5 mm.													

NO	Item	Criterion	Level																												
06	<p>Black or white dot、scratch、contamination</p> <p>Round type</p>  <p>$\Phi = (x + y) / 2$</p> <p>Line type</p> 	<p>6. 1 Round type (Non-display or display) :</p> <table border="1" data-bbox="523 477 1252 846"> <thead> <tr> <th>Dimension (diameter : Φ)</th> <th>Acceptance (Q'ty)</th> </tr> </thead> <tbody> <tr> <td>$\Phi \leq 0.25$</td> <td>Ignore</td> </tr> <tr> <td>$0.25 < \Phi \leq 0.50$</td> <td>5</td> </tr> <tr> <td>$\Phi > 0.50$</td> <td>0</td> </tr> <tr> <td>Total</td> <td>5</td> </tr> </tbody> </table> <p>6. 2 Line type(Non-display or display) :</p> <table border="1" data-bbox="497 1003 1279 1444"> <thead> <tr> <th>Length (L)</th> <th>Width (W)</th> <th>Acceptance (Q'ty)</th> </tr> </thead> <tbody> <tr> <td>---</td> <td>$W \leq 0.03$</td> <td>Ignore</td> </tr> <tr> <td>$L \leq 10.0$</td> <td>$0.03 < W \leq 0.05$</td> <td>4</td> </tr> <tr> <td>$L \leq 5.0$</td> <td>$0.05 < W \leq 0.10$</td> <td>2</td> </tr> <tr> <td>---</td> <td>$W > 0.10$</td> <td>As round type</td> </tr> <tr> <td colspan="2">Total</td> <td>5</td> </tr> </tbody> </table>	Dimension (diameter : Φ)	Acceptance (Q'ty)	$\Phi \leq 0.25$	Ignore	$0.25 < \Phi \leq 0.50$	5	$\Phi > 0.50$	0	Total	5	Length (L)	Width (W)	Acceptance (Q'ty)	---	$W \leq 0.03$	Ignore	$L \leq 10.0$	$0.03 < W \leq 0.05$	4	$L \leq 5.0$	$0.05 < W \leq 0.10$	2	---	$W > 0.10$	As round type	Total		5	Minor
Dimension (diameter : Φ)	Acceptance (Q'ty)																														
$\Phi \leq 0.25$	Ignore																														
$0.25 < \Phi \leq 0.50$	5																														
$\Phi > 0.50$	0																														
Total	5																														
Length (L)	Width (W)	Acceptance (Q'ty)																													
---	$W \leq 0.03$	Ignore																													
$L \leq 10.0$	$0.03 < W \leq 0.05$	4																													
$L \leq 5.0$	$0.05 < W \leq 0.10$	2																													
---	$W > 0.10$	As round type																													
Total		5																													
07	Polarizer Bubble	<table border="1" data-bbox="491 1541 1289 1944"> <thead> <tr> <th>Dimension (diameter : Φ)</th> <th>Acceptance (Q'ty)</th> </tr> </thead> <tbody> <tr> <td>$\Phi \leq 0.25$</td> <td>Ignore</td> </tr> <tr> <td>$0.25 < \Phi \leq 0.50$</td> <td>4</td> </tr> <tr> <td>$0.50 < \Phi \leq 0.80$</td> <td>1</td> </tr> <tr> <td>$\Phi > 0.80$</td> <td>0</td> </tr> <tr> <td>Total</td> <td>5</td> </tr> </tbody> </table>	Dimension (diameter : Φ)	Acceptance (Q'ty)	$\Phi \leq 0.25$	Ignore	$0.25 < \Phi \leq 0.50$	4	$0.50 < \Phi \leq 0.80$	1	$\Phi > 0.80$	0	Total	5	Minor																
Dimension (diameter : Φ)	Acceptance (Q'ty)																														
$\Phi \leq 0.25$	Ignore																														
$0.25 < \Phi \leq 0.50$	4																														
$0.50 < \Phi \leq 0.80$	1																														
$\Phi > 0.80$	0																														
Total	5																														

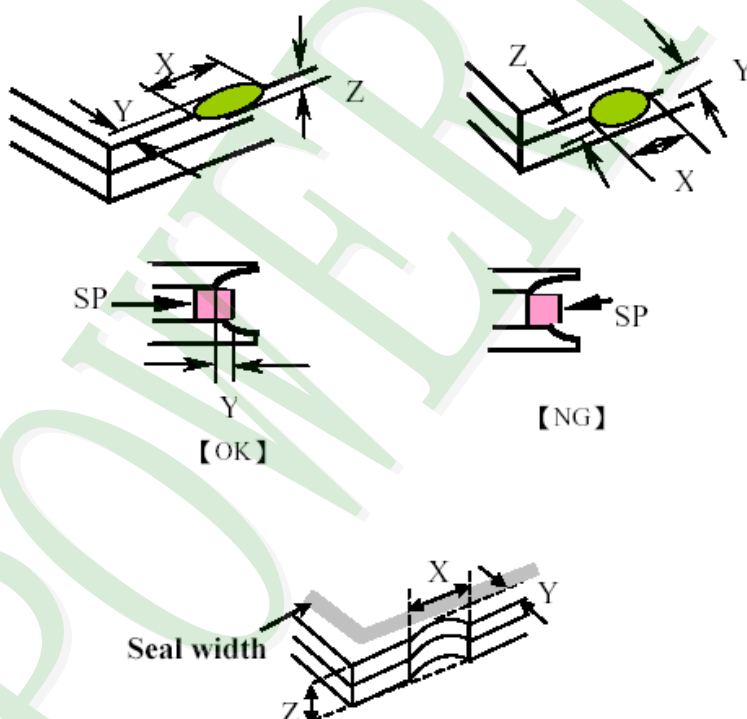
NO	Item	Criterion	Level						
08	The crack of glass	Symbols : X : The length of crack Z : The thickness of crack t : The thickness of glass Y : The width of crack. W : terminal length a : LCD side length	Minor						
		8.1 General glass chip : 8.1.1 Chip on panel surface and crack between panels:  <table border="1" data-bbox="542 1601 1348 1892"> <thead> <tr> <th>X</th> <th>Y</th> <th>Z</th> </tr> </thead> <tbody> <tr> <td>$\leq a$</td> <td>Crack can't enter viewing area</td> <td>$\leq 1/2 t$</td> </tr> <tr> <td>$\leq a$</td> <td>Crack can't exceed the half of SP width.</td> <td>$1/2 t < Z \leq 2 t$</td> </tr> </tbody> </table>		X	Y	Z	$\leq a$	Crack can't enter viewing area	$\leq 1/2 t$
X	Y	Z							
$\leq a$	Crack can't enter viewing area	$\leq 1/2 t$							
$\leq a$	Crack can't exceed the half of SP width.	$1/2 t < Z \leq 2 t$							

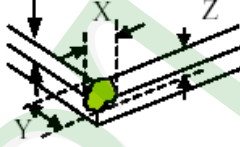
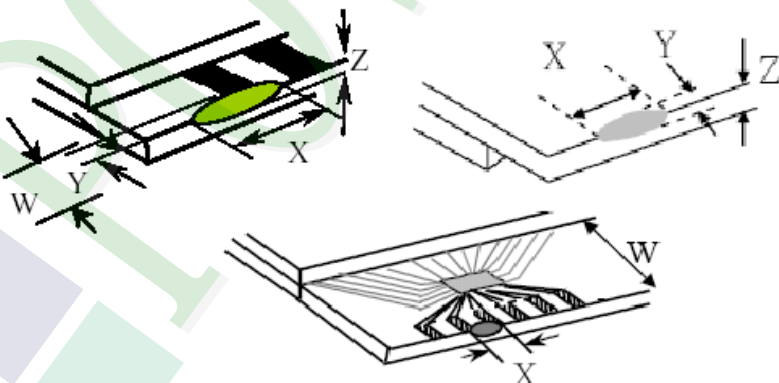
NO	Item	Criterion	Level										
08	The crack of glass	<p>Symbols :</p> <p>X : The length of crack Z : The thickness of crack t : The thickness of glass</p> <p>Y : The width of crack. W : terminal length a : LCD side length</p> <hr/> <p>8.1.2 Corner crack :</p>  <table border="1" data-bbox="529 835 1326 1120"> <thead> <tr> <th>X</th> <th>Y</th> <th>Z</th> </tr> </thead> <tbody> <tr> <td>$\leq 1/5 a$</td> <td>Crack can't enter viewing area</td> <td>$Z \leq 1/2 t$</td> </tr> <tr> <td>$\leq 1/5 a$</td> <td>Crack can't exceed the half of SP width.</td> <td>$1/2 t < Z \leq 2 t$</td> </tr> </tbody> </table>	X	Y	Z	$\leq 1/5 a$	Crack can't enter viewing area	$Z \leq 1/2 t$	$\leq 1/5 a$	Crack can't exceed the half of SP width.	$1/2 t < Z \leq 2 t$	Minor	
		X	Y	Z									
$\leq 1/5 a$	Crack can't enter viewing area	$Z \leq 1/2 t$											
$\leq 1/5 a$	Crack can't exceed the half of SP width.	$1/2 t < Z \leq 2 t$											
<p>8.2 Protrusion over terminal :</p> <p>8.2.1 Chip on electrode pad :</p>  <table border="1" data-bbox="566 1697 1334 1865"> <thead> <tr> <th></th> <th>X</th> <th>Y</th> <th>Z</th> </tr> </thead> <tbody> <tr> <td>Front</td> <td>$\leq a$</td> <td>$\leq 1/2 W$</td> <td>$\leq t$</td> </tr> <tr> <td>Back</td> <td>$\leq a$</td> <td>$\leq W$</td> <td>$\leq 1/2 t$</td> </tr> </tbody> </table>		X	Y	Z	Front	$\leq a$	$\leq 1/2 W$	$\leq t$	Back	$\leq a$	$\leq W$	$\leq 1/2 t$	
	X	Y	Z										
Front	$\leq a$	$\leq 1/2 W$	$\leq t$										
Back	$\leq a$	$\leq W$	$\leq 1/2 t$										

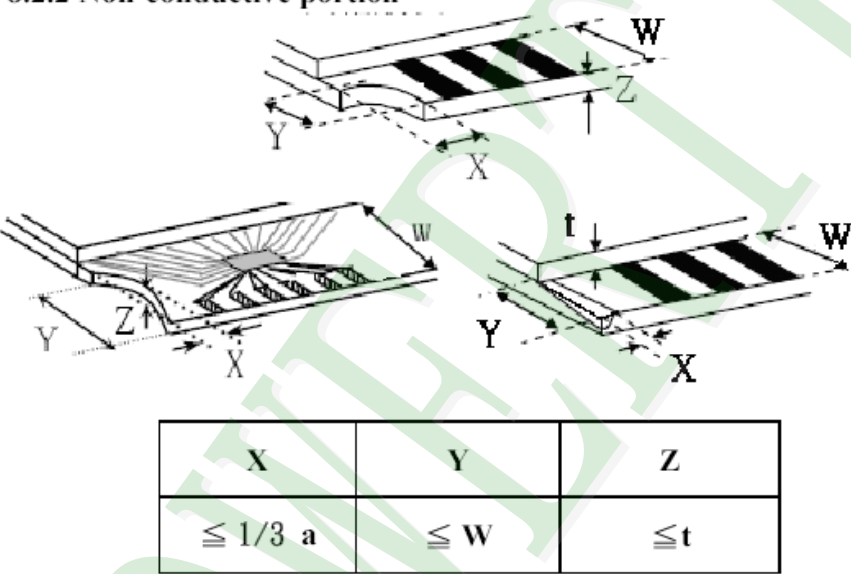
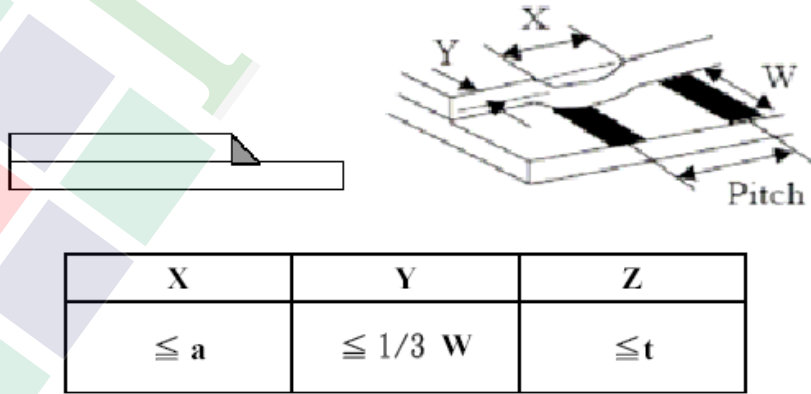
NO	Item	Criterion	Level
08	The crack of glass	<p>Symbols :</p> <p>X : The length of crack Y : The width of crack. Z : The thickness of crack W : terminal length t : The thickness of glass a : LCD side length</p>	Minor
		<p>8.2.2 Non-conductive portion :</p>  <p>⊙ If the chipped area touches the ITO terminal, over 2/3 of the ITO must remain and be inspected according to electrode terminal specifications.</p> <p>8.2.3 Glass remain :</p> 	

◆Specification For TFT-LCD Module 3.5" ~10" :

(Ver. 02)

NO	Item	Criterion	Level
09	Backlight elements	9. 1 Backlight can't work normally.	Major
		9. 2 Backlight doesn't light or color is wrong.	Major
		9. 3 Illumination source flickers when lit.	Major
10	General appearance	10. 1 Pin type 、 quantity 、 dimension must match type in structure diagram.	Major
		10. 2 No short circuits in components on PCB or FPC .	Major
		10. 3 Parts on PCB or FPC must be the same as on the production characteristic chart .There should be no wrong parts , missing parts or excess parts.	Major
		10. 4 Product packaging must the same as specified on packaging specification sheet.	Minor
		10. 5 The folding and peeled off in polarizer are not acceptable.	Minor
		10. 6 The PCB or FPC between B/L assembled distance(PCB or FPC) is ≤ 1.5 mm.	Minor

4.1 Reliability Test Condition

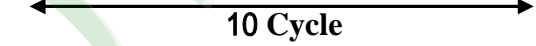
NO.	TEST ITEM	TEST CONDITION										
1	High Temperature Storage Test	Keep in +80 ±2°C 96 hrs Surrounding temperature, then storage at normal condition 4hrs.										
2	Low Temperature Storage Test	Keep in -30 ±2°C 96 hrs Surrounding temperature, then storage at normal condition 4hrs.										
3	High Temperature / High Humidity Storage Test	Keep in +60°C / 90% R.H duration for 96 hrs Surrounding temperature, then storage at normal condition 4hrs. (Excluding the polarizer & T/P)										
4	ESD Test	<table border="1"> <tr> <td> Air Discharge: (include mobile phone) Apply 2 KV with 5 times Discharge for each polarity +/- </td> <td> Contact Discharge: (include mobile phone) Apply 250V with 5 times discharge for each polarity +/- </td> </tr> </table>	Air Discharge: (include mobile phone) Apply 2 KV with 5 times Discharge for each polarity +/-	Contact Discharge: (include mobile phone) Apply 250V with 5 times discharge for each polarity +/-								
		Air Discharge: (include mobile phone) Apply 2 KV with 5 times Discharge for each polarity +/-	Contact Discharge: (include mobile phone) Apply 250V with 5 times discharge for each polarity +/-									
<ol style="list-style-type: none"> Temperature ambience: 15°C ~ 35°C Humidity relative: 30% ~ 60% Energy Storage Capacitance(Cs+Cd): 150pF±10% Discharge Resistance(Rd): 330Ω±10% Discharge, mode of operation: Single Discharge (time between successive discharges at least 1 s) (Tolerance if the output voltage indication: ±5%) 												
5	Temperature Cycling Storage Test	<p style="text-align: center;"> -20°C → +25°C → +70°C → +25°C (30mins) (30mins) (30mins) (30mins)  10 Cycle </p> <p>Surrounding temperature, then storage at normal condition 4hrs.</p>										
6	Vibration Test (Packaged)	<ol style="list-style-type: none"> Sine wave 10 ~ 55 Hz frequency (1 min) The amplitude of vibration : 1.5 mm Each direction (X、Y、Z) duration for 2 Hrs 										
7	Drop Test (Packaged)	<table border="1"> <thead> <tr> <th>Packing Weight (Kg)</th> <th>Drop Height (cm)</th> </tr> </thead> <tbody> <tr> <td>0 ~ 45.4</td> <td>122</td> </tr> <tr> <td>45.4 ~ 90.8</td> <td>76</td> </tr> <tr> <td>90.8 ~ 454</td> <td>61</td> </tr> <tr> <td>Over 454</td> <td>46</td> </tr> </tbody> </table> <p>Drop direction : ※ 1 corner / 3 edges / 6 sides each 1times</p>	Packing Weight (Kg)	Drop Height (cm)	0 ~ 45.4	122	45.4 ~ 90.8	76	90.8 ~ 454	61	Over 454	46
Packing Weight (Kg)	Drop Height (cm)											
0 ~ 45.4	122											
45.4 ~ 90.8	76											
90.8 ~ 454	61											
Over 454	46											

5. PRECAUTION RELATING PRODUCT HANDLING

5.1 SAFETY

- 5.1.1 If the LCD panel breaks , be careful not to get the liquid crystal to touch your skin.
- 5.1.2 If the liquid crystal touches your skin or clothes , please wash it off immediately by using soap and water.

5.2 HANDLING

- 5.2.1 Avoid any strong mechanical shock which can break the glass.
- 5.2.2 Avoid static electricity which can damage the CMOS LSI—When working with the module , be sure to ground your body and any electrical equipment you may be using.
- 5.2.3 Do not remove the panel or frame from the module.
- 5.2.4 The polarizing plate of the display is very fragile. So , please handle it very carefully, do not touch , push or rub the exposed polarizing with anything harder than an HB pencil lead (glass , tweezers , etc.)
- 5.2.5 Do not wipe the polarizing plate with a dry cloth , as it may easily scratch the surface of plate.
- 5.2.6 Do not touch the display area with bare hands , this will stain the display area.
- 5.2.7 Do not use ketonics solvent & aromatic solvent. Use with a soft cloth soaked with a cleaning naphtha solvent.
- 5.2.8 To control temperature and time of soldering is $320 \pm 10^{\circ}\text{C}$ and 3-5 sec.
- 5.2.9 To avoid liquid (include organic solvent) stained on LCM

5.3 STORAGE

- 5.3.1 Store the panel or module in a dark place where the temperature is $25^{\circ}\text{C} \pm 5^{\circ}\text{C}$ and the humidity is below 65% RH.
- 5.3.2 Do not place the module near organics solvents or corrosive gases.
- 5.3.3 Do not crush , shake , or jolt the module.

5.4 TERMS OF WARRANTY

- 5.4.1 Applicable warrant period
The period is within thirteen months since the date of shipping out under normal using and storage conditions.
- 5.4.2 Unaccepted responsibility
This product has been manufactured to your company's specification as a part for use in your company's general electronic products. It is guaranteed to perform according to delivery specifications. For any other use apart from general electronic equipment, we cannot take responsibility if the product is used in nuclear power control equipment, aerospace equipment , fire and security systems or any other applications in which there is a direct risk to human life and where extremely high levels of reliability are required.

A B C D E F G H

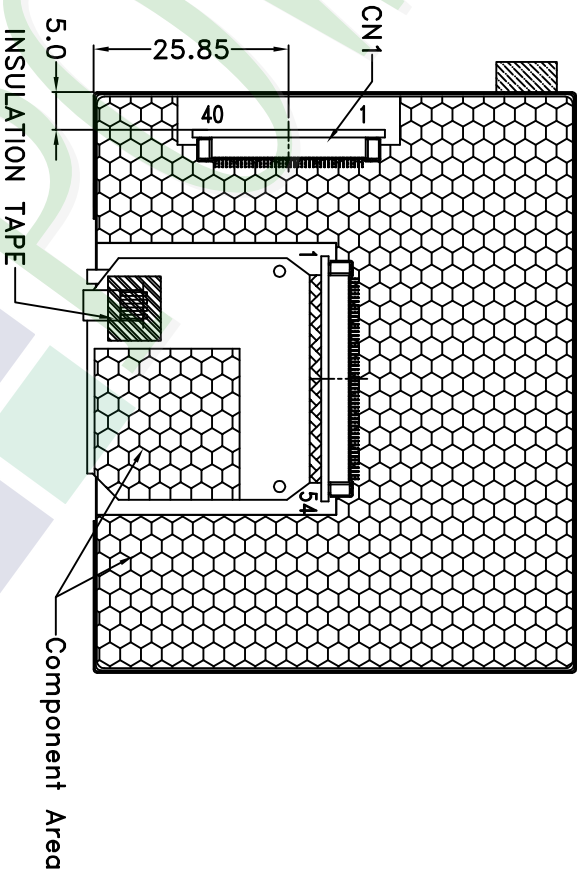
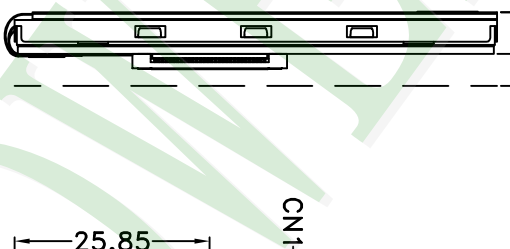
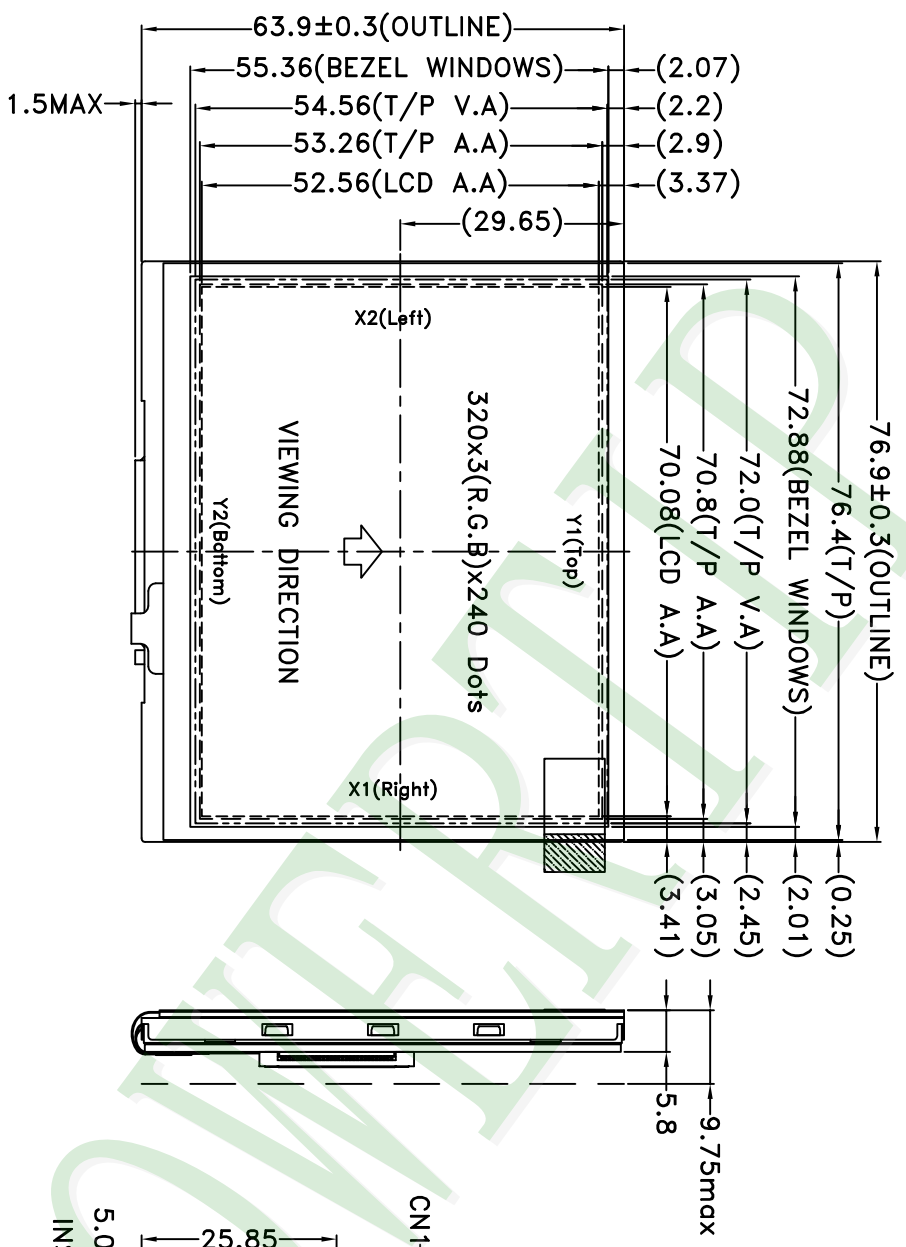

- NOTES:
 1. LCD TYPE: a-Si TFT
 2. LCD DISPLAY: TRANSMISSIVE
 3. VIEW DIRECTION: 6 O'CLOCK
 4. The tolerance unless classified ±0.3mm
 5. CN1: IMSA-9637S-40Y923

007				
006				
005				
004				
003				
002				
001	NEW DRAWING	Stone	2008/02/15	
REV	REV BY	REVISER	DATE	

PART NO:	PH320240T-015-102Q
DRAWING NAME:	LMD-PH320240T-015-102Q
TITLE:	LCD Module Drawing

Design	Steno
Check	Mag
Approve	Oliver

久正光電股份有限公司	
POWER TIP TECHNOLOGY CORPORATION	
Unit	MM
Scale	1:1
Page	1/1
Surface	Material
Thickness	Quantity
公差標準	精級
1 ~ 4	-
16 ~ 63	-
63 ~ 250	-
250 ~ 1000	-

1 2 3 4 5 6

Ver.001

Documents NO. PKG-PH320240T-015-I02Q

LCM包裝規格書

LCM Packaging Specifications

Approve	Check	Contact
Oliver	Mag	Stone

1. 包裝材料規格表 (Packaging Material) : (per carton)

No.	Item	Model	Dimensions (mm)	1Pcs Weight	Quantity	Total Weight
1	成品 (LCM)	PH320240T-015-I02Q	76.9 X 63.9	0.0547	288	15.754
2	靜電袋(1)Antistatic Bag	BAG150120ARABA	150 X 120	0.0018	288	0.5184
3	氣泡袋(2)Bubble Bag	BAG240100AWBBA	240 X 100	0.001	288	0.288
4	A2隔板(3)A2 Partition	BX29300070BMBA	293 X 70 X 2.5	0.011	88	0.968
5	B2隔板(4)B2 Partition	BX24500070BLBA	245 X 70 X 2.5	0.01	32	0.32
6	氣泡紙(5)Bubble Sheet	BAG280240BWABA	280 X 240	0.006	16	0.096
7	C2內盒(6)Product Box	BX31025580AABA	310 X 255 X 80	0.221	8	1.768
8	外紙箱(7)Carton	BX52732536CCBA	527 X 325 X 360	1.092	1	1.092
9						

2. 一整箱總重量 (Total LCD Weight in carton) : 20.81 Kg±10%

3. 單箱數量規格表 (Packaging Specifications and Quantity) :

(1)Quantity Of Spacer : A2隔板 X 11 , B2隔板 X 4

(2)Total LCM quantity in carton : quantity per box 36 x no of boxes 8 = 288

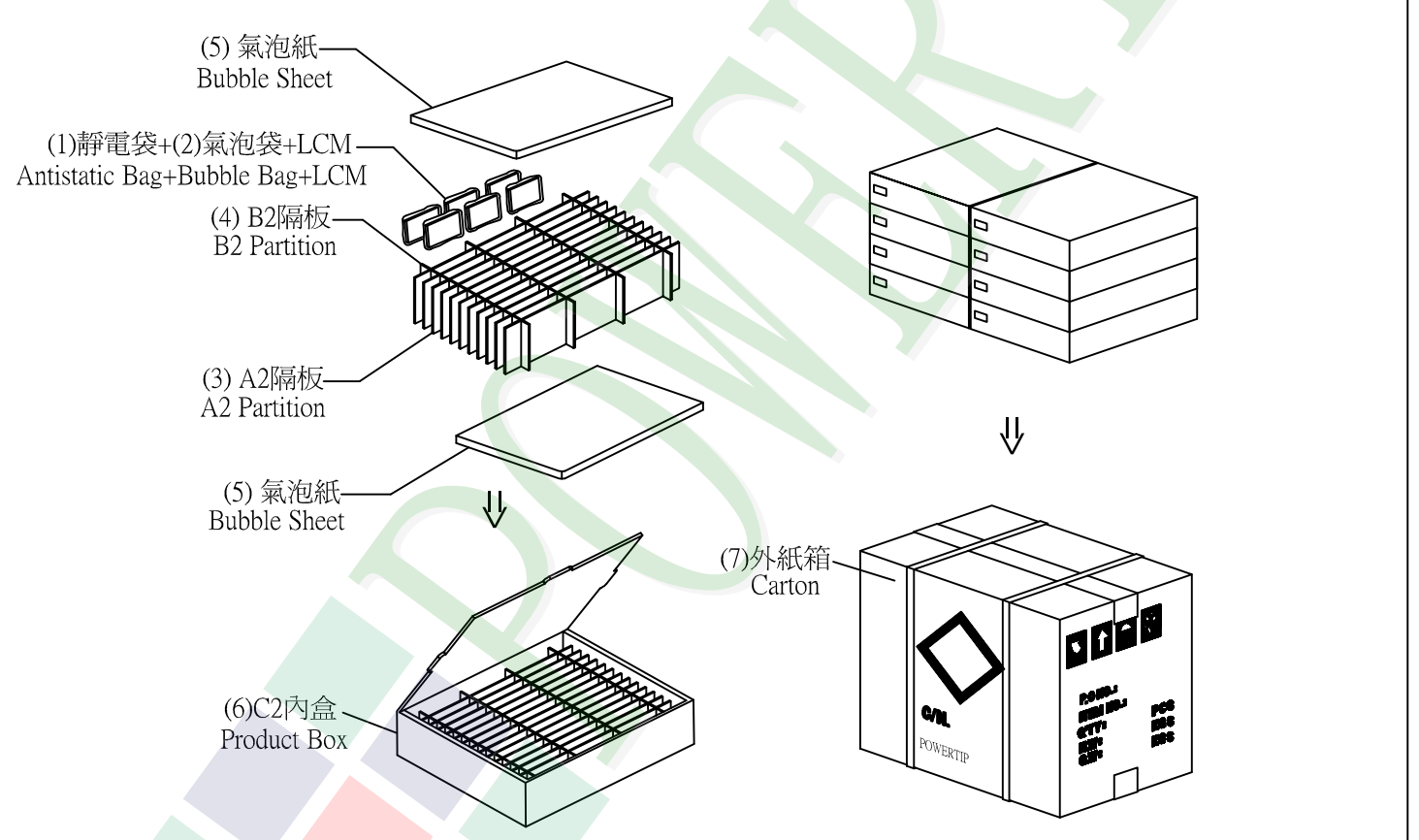

特 記 事 項 (REMARK)

1. Label Specifications :

MODEL:
 LOT NO:
 QUANTITY:
 CHECK: