



# APPROVAL SHEET

## 承 認 書

Customer 客戶名稱	
Part No. 產品型號	GPG48273QS5
Product type 產品內容	4.3" TFT module: Transmissive Type, Positive mode , RGB vertical stripe
RoHS 綠色產品	<input type="checkbox"/> Non-compliance <input checked="" type="checkbox"/> Compliance
Remarks 備註欄	
<input type="checkbox"/> Preliminary Specification 暫行規格 <input checked="" type="checkbox"/> Final Specification 正式規格	
Signature by Customer: 客戶確認簽章:	

Issued by	Checked by		Checked by	Approved By	
	QA	QA		QA	BU
QA 李淑惠 07/17	廖和信 07/17	徐利敏 07/17	李光輝 07/17	蔡建銘 07/17	廖和信 07/17



## Specification of LCD Module

Product No.: GPG48273QS5

Issue date: 2008/9/22

Giantplus Technology Co., LTD

15 Industrial Rd., Lu-Chu Li, Toufen Chen

Miao-Li Hsien, 351 Taiwan.

TEL: 886-37-611-611

FAX: 886-37-613-166



## TABLE OF CONTENTS

<b>1. GENERAL DESCRIPTION .....</b>	<b>5</b>
<b>2. FEATURES .....</b>	<b>5</b>
<b>3. MECHANICAL SPECIFICATION .....</b>	<b>5</b>
<b>4. MECHANICAL DIMENSION.....</b>	<b>6</b>
<b>5. MAXIMUM RATINGS .....</b>	<b>7</b>
<b>6. ELECTRICAL CHARACTERISTICS.....</b>	<b>8</b>
6.1. TFT LCD Characteristic .....	8
6.2. Backlight Characteristic .....	8
<b>7. MODULE FUNCTION DESCRIPTION .....</b>	<b>9</b>
7.1. PIN Description .....	9
7.2. Timing characteristics .....	11
<b>8. TOUCH PANEL.....</b>	<b>13</b>
8.1. Electrical Characteristics.....	13
8.2. Mech. & Reliability Characteristics.....	13
8.3. Integration Design Guide .....	14
<b>9. ELECTRO-OPTICAL CHARACTERISTICS .....</b>	<b>15</b>
<b>10. RELIABILITY.....</b>	<b>17</b>
10.1. TESTS.....	17
10.2. Color Performance .....	17
<b>11. ILLUSTRATION OF LCD DATE CODE(GP) .....</b>	<b>18</b>
<b>12. ILLUSTRATION OF LCD DATE CODE(KGP).....</b>	<b>19</b>
<b>13. ROHS COMPLIANT WARRANTY.....</b>	<b>20</b>
<b>14. PRECAUTIONS FOR USE .....</b>	<b>20</b>
14.1. Safety .....	20
14.2. Storage Conditions.....	20
14.3. Installing LCD Module .....	20



14.4.	Precautions For Operation .....	21
14.5.	Handling Precautions .....	21
14.6.	Warranty.....	21
<b>15.</b>	<b>FACTORY .....</b>	<b>22</b>
<b>16.</b>	<b>REVISION HISTORY.....</b>	<b>22</b>



## 1. GENERAL DESCRIPTION

GPG48273QS5 is a Transmissive type color active matrix liquid crystal display (LCD), which uses amorphous thin film transistor (TFT) as switching devices. This product is composed of a TFT LCD panel, driver ICs, FPC, touch panel and a backlight unit. The following table described the features of GPG48273QS5

## 2. FEATURES

Display Mode	Transmissive Type
	TFT LCD, Normally white
Display Format	RGB Strip type
Color	16.7M color
Interface	RGB data bus, 24 bit parallel data
Viewing Direction	6 O'clock
Backlight type / color	LED / White
Touch panel	4 Wire Analog Type (Haze:8)

## 3. MECHANICAL SPECIFICATION

Item	Specifications	Unit
Display Size	4.3	Inch
Dimensional outline	105.5 (W) × 67.2 (H) × 4.2 (D)*	mm
Resolution	480×3(R,G,B)×272	dot
Active area	95.04 (W) × 53.856 (H)	mm
Pixel pitch	0.198 (W) × 0.18 (H)	mm
Polarizer	Anti-Glare	

\* Exclude FPC



Giantplus  
Technology

RoHS  
COMPLIANT

## 4. MECHANICAL DIMENSION

Customer's Approval

Customer

Date

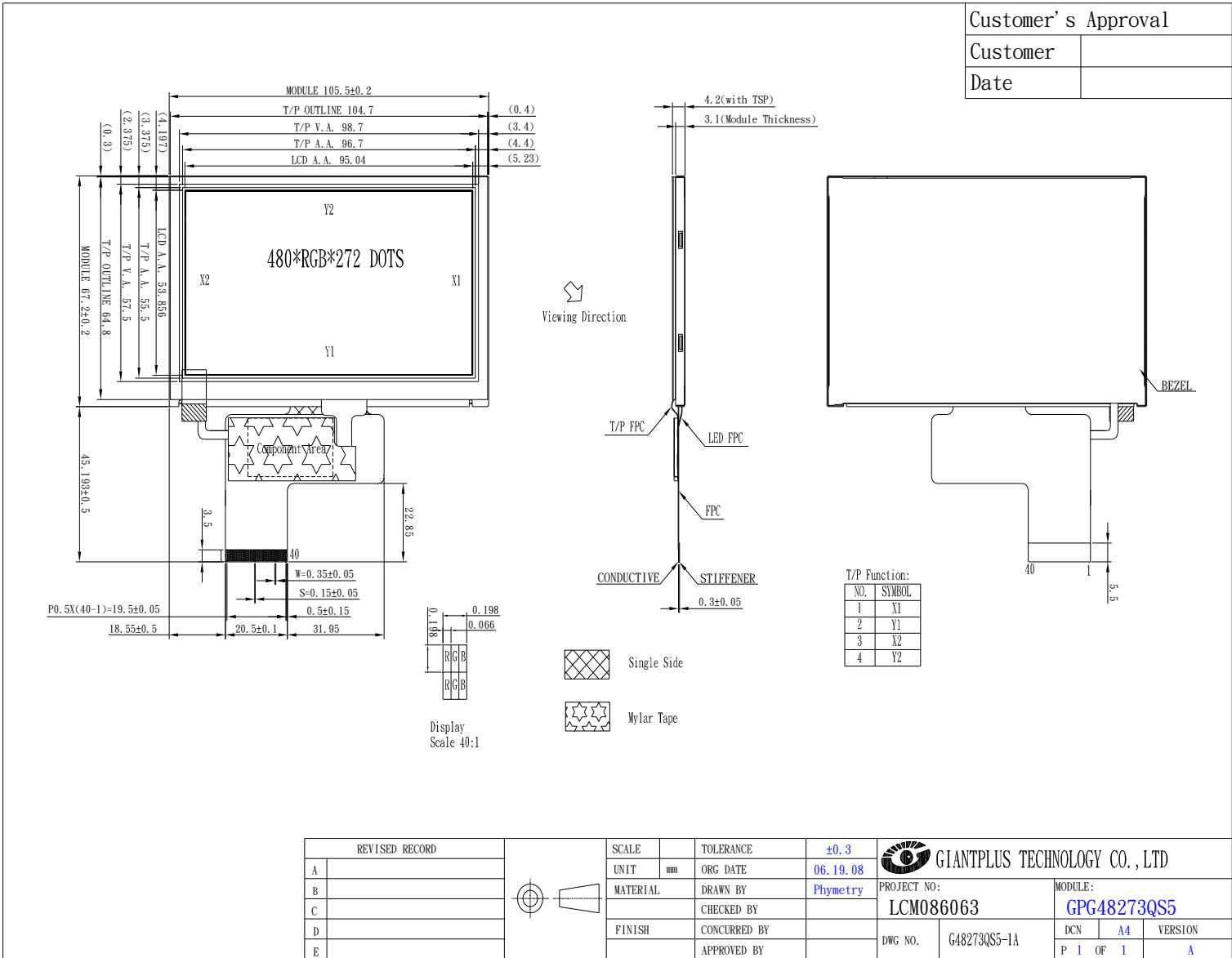



## 5. MAXIMUM RATINGS

ITEM	SYMBOL	MIN.	MAX.	UNIT
Digital supply voltage	VDDIO	-0.3	+4.5	V
Power Supply for Pump	VDD	-0.3	+4.5	V
Analog supply voltage	VDD2	-0.3	+7.0	V
Operation Temperature	T <sub>A</sub>	-20	70	°C
Storage Temperature	T <sub>stg</sub>	-30	80	°C
Humidity	-	-	90	%RH

Note:

- a. All of voltage listed above are with respective to GND=VSS=0V.
- b. Device is subject to be damaged permanently if stresses beyond those absolute maximum ratings listed above.
- c: T<sub>A</sub> ≤ 40°C Without dewing.



## 6. ELECTRICAL CHARACTERISTICS

### 6.1. TFT LCD Characetristic

Typical operating conditions

(GND=AVSS=0V)

Item	Symbol	Min.	Typ.	Max.	Unit	Note
Power supply(VCI)	VDD	3.0	3.3	3.6	V	
	AVDD	4.8	5.0	5.2	V	
Current	I <sub>dd</sub>	-	(12)	-	mA	
Driver Input signal voltage	H	V <sub>IH</sub>	0.7*VDD	-	VDD	V
	L	V <sub>IL</sub>	0	-	0.3*VDD	V

### 6.2. Backlight Characteristic

Item	Symbol	Values			Unit	Remark
		Min.	Typ.	Max.		
Power Consumption	P <sub>LED</sub>	-	660	-	mW	
LED Current	I <sub>L</sub>	-	40	-	mA	5series*2parallel =40mA
LED Voltage	V <sub>L</sub>	-	16.5	-	V	

**Note1: GP suggest using constant current driving this backlight unit.**



## 7. MODULE FUNCTION DESCRIPTION

### 7.1. PIN Description

Pin	Symbol	Description	Remark
1	VLED-	Power for LED	
2	VLED+	Power for LED	
3	GND	Power Ground	
4	VDD	Power supply	
5	R0	Red data (LSB)	
6	R1	Red data	
7	R2	Red data	
8	R3	Red data	
9	R4	Red data	
10	R5	Red data	
11	R6	Red data	
12	R7	Red data (MSB)	
13	G0	Green data (LSB)	
14	G1	Green data	
15	G2	Green data	
16	G3	Green data	
17	G4	Green data	
18	G5	Green data	
19	G6	Green data	
20	G7	Green data (MSB)	
21	B0	Blue data (LSB)	
22	B1	Blue data	
23	B2	Blue data	
24	B3	Blue data	
25	B4	Blue data	
26	B5	Blue data	
27	B6	Blue data	
28	B7	Blue data (MSB)	
29	GND	Power ground	



30	PCLK	Pixel clock	
31	DISP	Display on/off	
32	HSYNC	Horizontal sync signal	
33	VSYNC	Vertical sync signal	
34	DE	Data enable	
35	AVDD	Power supply(+5V)	
36	GND	Power ground	
37	X1	Right side of touch panel	
38	Y1	Bottom side of touch panel	
39	X2	Left side of touch panel t	
40	Y2	Up side of touch panel	



## 7.2. Timing characteristics

### 7.2.1. Timing Chart.

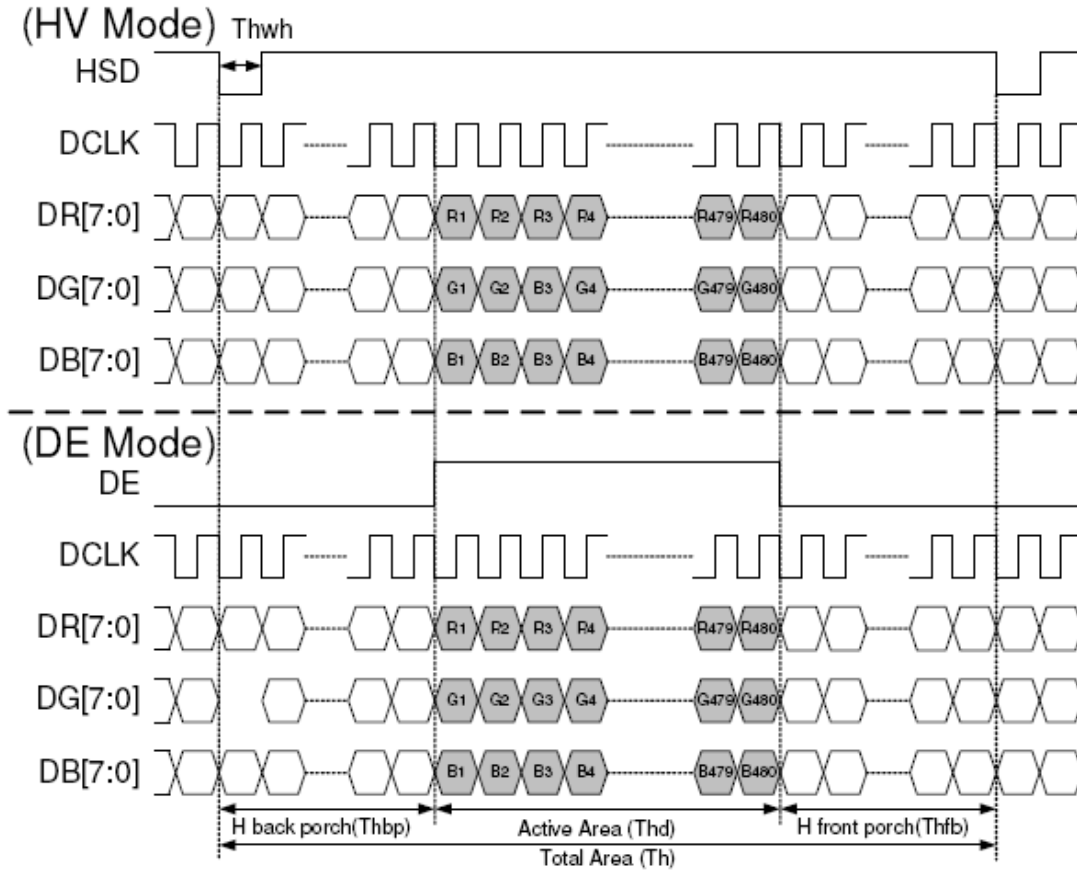

### 7.2.2. Timing Specification

Parameter	Symbol	Value			Unit
		Min.	Typ.	Max.	
DCLK frequency	fclk	5	9	12	MHz
VSD period time	Tv	277	288	400	H
VSD display area	Tvd	272			H
VSD back porch	Tvb	3	8	31	H
VSD front porch	Tvfp	2	8	93	H
HSD period time	Th	520	525	800	DCLK
HSD display area	Thd	480			DCLK
HSD back porch	Thbp	36	40	255	DCLK
HSD front porch	Thfp	4	5	65	DCLK



7.2.3.Color data Assignment

COLOR	INPUT DATA	R DATA								G DATA								B DATA							
		R7	R6	R5	R4	R3	R2	R1	R0	R7	R6	R5	R4	R3	R2	R1	R0	R7	R6	R5	R4	R3	R2	R1	R0
		MSB							LSB	MSB							LSB	MSB							LSB
BASIC COLOR	BLACK	0	0	0	0	0	0	0	0	0	0	0	0	0	0	0	0	0	0	0	0	0	0	0	0
	RED(255)	1	1	1	1	1	1	1	1	0	0	0	0	0	0	0	0	0	0	0	0	0	0	0	0
	GREEN(255)	0	0	0	0	0	0	0	0	1	1	1	1	1	1	1	1	0	0	0	0	0	0	0	0
	BLUE(255)	0	0	0	0	0	0	0	0	0	0	0	0	0	0	0	0	1	1	1	1	1	1	1	1
	CYAN	0	0	0	0	0	0	0	0	1	1	1	1	1	1	1	1	1	1	1	1	1	1	1	1
	MAGENTA	1	1	1	1	1	1	1	1	0	0	0	0	0	0	0	0	1	1	1	1	1	1	1	1
	YELLOW	1	1	1	1	1	1	1	1	1	1	1	1	1	1	1	1	0	0	0	0	0	0	0	0
WHITE	1	1	1	1	1	1	1	1	1	1	1	1	1	1	1	1	1	1	1	1	1	1	1	1	
RED	RED(0)	0	0	0	0	0	0	0	0	0	0	0	0	0	0	0	0	0	0	0	0	0	0	0	0
	RED(1)	0	0	0	0	0	0	0	1	0	0	0	0	0	0	0	0	0	0	0	0	0	0	0	0
	RED(2)	0	0	0	0	0	0	1	0	0	0	0	0	0	0	0	0	0	0	0	0	0	0	0	0
	RED(254)	1	1	1	1	1	1	1	0	0	0	0	0	0	0	0	0	0	0	0	0	0	0	0	0
	RED(255)	1	1	1	1	1	1	1	1	0	0	0	0	0	0	0	0	0	0	0	0	0	0	0	0
GREEN	GREEN(0)	0	0	0	0	0	0	0	0	0	0	0	0	0	0	0	0	0	0	0	0	0	0	0	0
	GREEN(1)	0	0	0	0	0	0	0	0	0	0	0	0	0	0	0	1	0	0	0	0	0	0	0	0
	GREEN(2)	0	0	0	0	0	0	0	0	0	0	0	0	0	0	1	0	0	0	0	0	0	0	0	0
	GREEN(254)	0	0	0	0	0	0	0	0	1	1	1	1	1	1	1	0	0	0	0	0	0	0	0	0
GREEN(255)	0	0	0	0	0	0	0	0	1	1	1	1	1	1	1	1	0	0	0	0	0	0	0	0	
BLUE	BLUE (0)	0	0	0	0	0	0	0	0	0	0	0	0	0	0	0	0	0	0	0	0	0	0	0	0
	BLUE (1)	0	0	0	0	0	0	0	0	0	0	0	0	0	0	0	0	0	0	0	0	0	0	0	1
	BLUE (2)	0	0	0	0	0	0	0	0	0	0	0	0	0	0	0	0	0	0	0	0	0	0	1	0
	BLUE (254)	0	0	0	0	0	0	0	0	0	0	0	0	0	0	0	0	1	1	1	1	1	1	1	0
BLUE (255)	0	0	0	0	0	0	0	0	0	0	0	0	0	0	0	0	1	1	1	1	1	1	1	1	

[NOTE] :

- 1) Definition of Gray level : Color(n) : n to show the Gray level , n is the more high and the light more bright.
- 2) Data:1-High, 0-Low.



## 8. TOUCH PANEL

### 8.1. Electrical Characteristics

Item	Min.	Typ.	Max.	Unit	Note
Linearity	-	-	±1.5	%	
Resistance between terminals	100	-	640	Ω	X (Film side)
	260	-	1240	Ω	Y (Glass side)
Insulation resistance	20M	-	-	Ω	
Operation voltage	-	-	5	V	
Response time	-	-	10	ms	
Transmittance	-	80	-	%	
Haze	-	8	-	%	

### 8.2. Mech. & Reliability Characteristics

Item	Min	Typ.	Max.	Unit	Note
Activation force	-	-	80	g	Note 1
Surface hardness	3	-	-	H	JIS-K5400
Durability-surface Sliding	Write 100,000	-	-	Characters	Note 2
Durability-surface Hitting	1000,000	-	-	Touch	Note 3

Note:

1. Stylus pen input: R 0.8mm polyacetal pen or finger.
2. Writing with R0.8mm plastic stylus pen, load 250gf in active area, Speed is 60mm/sec, each sliding length 30mm.
3. Writing with R8.0mm plastic stylus pen; load 250gf in active area, Speed is 3 times/sec.



### 8.3.Integration Design Guide

- Give enough clearance (over 0.3mm) between the touch-panel and a display to protect a display.

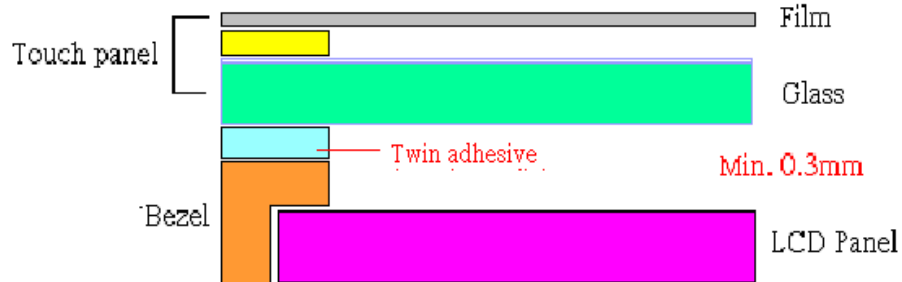

- Avoid the design that Front-case overlap and press on the active area of the touch-panel.
- Give enough gap (over 0.5mm at compressed) between the front case and touch-panel to protect wrong operating.

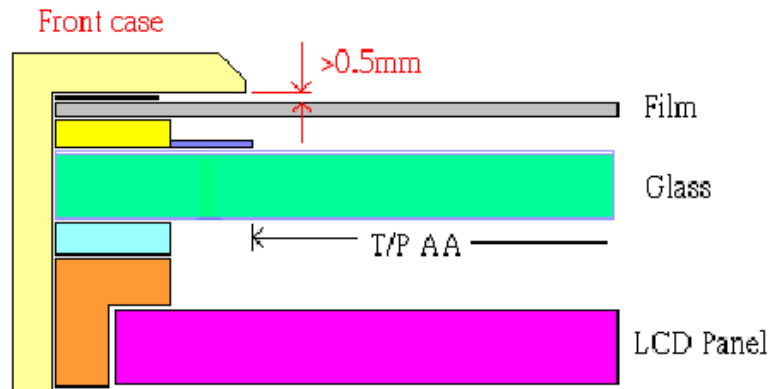

- Use a buffer material (Gasket) between the touch-panel and Front-case to protect damage and wrong operating.
- Avoid the design that buffer material (Gasket) overlap and press on the inside of touch-panel viewing area.

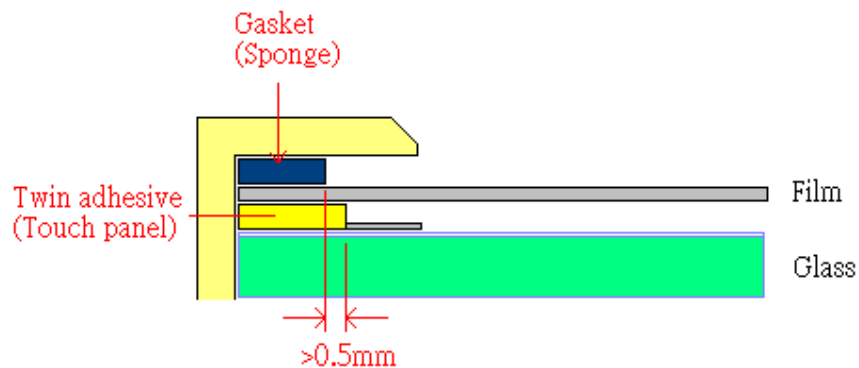

## 9. ELECTRO-OPTICAL CHARACTERISTICS

The following items are measured under stable conditions. The optical characteristics should be measured in dark room or equivalent state with the methods shown in Note 1.

Item		Symbol	Condition	Min	Typ	Max	Unit	Remark
Brightness				320	350	-	cd/m <sup>2</sup>	Note 2
Response time		$T_R+T_F$	$\Theta=0$	-	25	-	ms	Note 3
Contrast ratio		CR	At the center point of A.A.	300	500	-		Note 4
Color Chromaticity	White	$W_x$	$\Theta=0$	0.273	0.313	0.353		Note 5
		$W_y$		0.289	0.329	0.369		
Viewing Angle	$\varphi_H$	12	$CR \geq 10$	-	60	-	Degree	Note 6
	$\theta_R$	3		-	80	-		
	$\Phi_L$	6		-	75	-		
	$\Theta_L$	9		-	80	-		

$T_a=25\pm 2^\circ\text{C}$

Note:

1. Test equipment setup

After stabilizing and leaving the panel alone at a given temperature for 30 minutes, the measurement should be executed. Measurement should be executed in a stable, windless, and dark room. Optical specifications are measured by Topcon BM-5A with a viewing angle of  $2^\circ$  at a distance of 50cm and normal direction.

2. The Brightness data is without touch panel.

3. Definition of response time:  $T_R$  and  $T_F$

The figure below is the output signal of the photo detector.

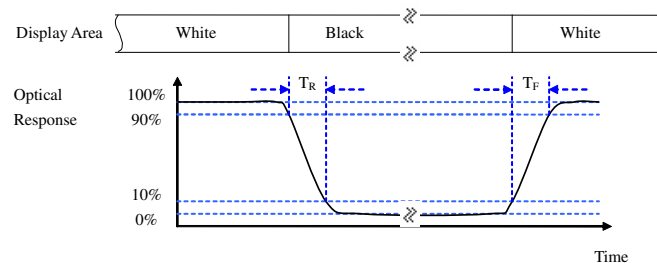

4. Definition of contrast ratio:

$$\text{Contrast ratio (CR)} = \frac{\text{Brightness measured when LCD is at "white state"}}{\text{Brightness measured when LCD is at "black state"}}$$

White  $V_i = V_{i50\%} \pm 1.5V$

Black  $V_i = V_{i50\%} \mu 2.0V$

" $\pm$ " means that the analog input signal swings in phase with VCOM signal.

" $\mu$ " means that the analog input signal swings out of phase with VCOM signal.

$V_{i50\%}$ : The analog input voltage when transmission is 50%.

The 100% transmission is defined as the transmission of LCD panel when all the input terminals of module are electrically opened.

5. Measured at the center area of the panel when all the input terminals of LCD panel are electrically opened.

6. Definition of viewing angle:

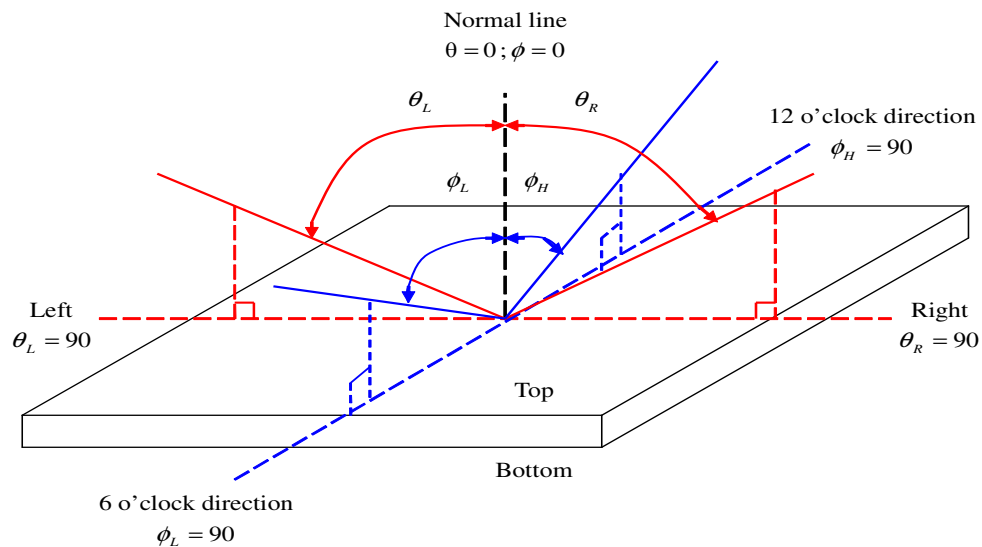

## 10.RELIABILITY

### 10.1.TESTS

NO.	ITEM	CONDITION	CRITERION
1	High Temperature Operating	70°C 240 hrs	◦ No Defect Of Operational Function In Room Temperature Are Allowable.
2	Low Temperature Operating	-20°C 240 hrs	
3	High Temperature/ Humidity Non-Operating	60°C ,90%RH ,240 hrs (No condensation)	
4	High Temperature Non-Operating	80°C 240 hrs	
5	Low Temperature Non-Operating	-30°C 240 hrs	
6	Temperature Shock Non-Operating	-30°C ←→ 80°C (30min) (5min) (30min) 100 CYCLES	
7	Electro-static Discharge	HBM : ±2kv	

Note 1: Test after 24 hours in room temperature.

Note 2: The sampling above is individually for each reliability testing condition.

Note 3: The color fading of polarizing filter should not care.

Note 4: All of the reliability testing chamber above, is using D.I. water.(Min value:1.0 MΩ-cm)

Note 5: In case of malfunction defect caused by ESD damage, if it would be recovered to normal state after resetting, it would be judged as a good part.

### 10.2.Color Performance

No.	ITEM	Criterion (initial)
1	Luminance	>50%
2	NTSC	>70%
3	Contrast Ratio	>50%



# 11. ILLUSTRATION OF LCD DATE CODE (GP)

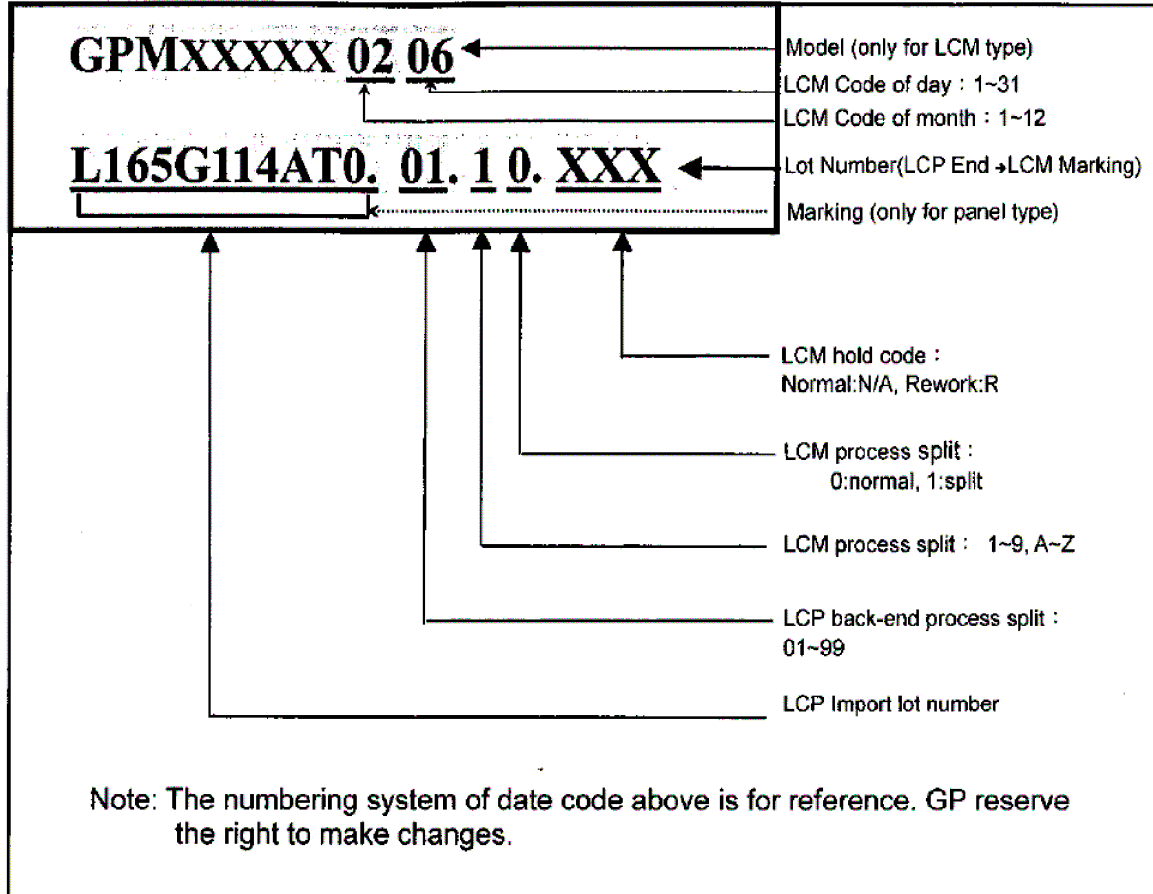



## 12. ILLUSTRATION OF LCD DATE CODE (KGP)

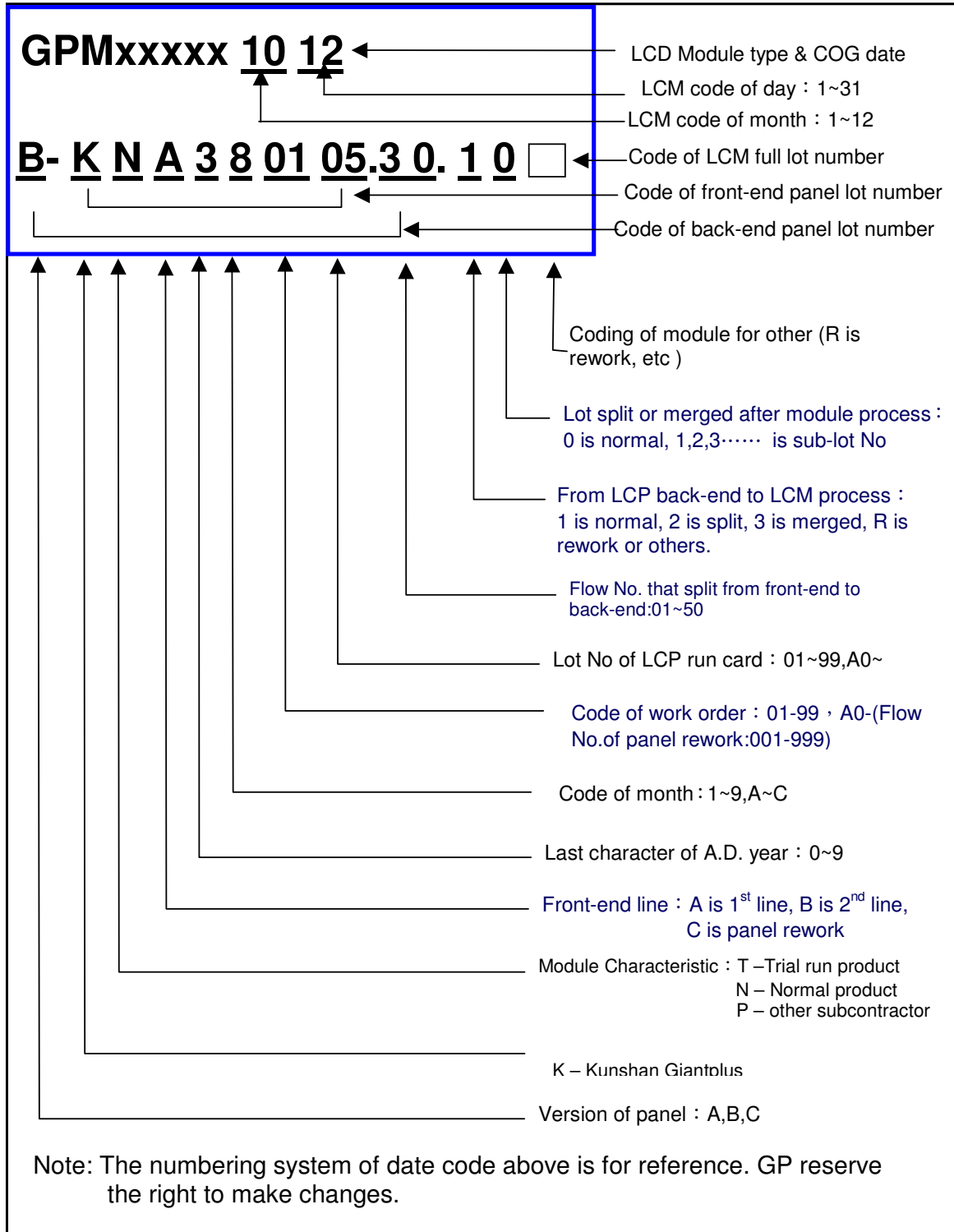



## 13. RoHS COMPLIANT WARRANTY

RoHS Hazardous substances including:

- Cd < 100 ppm
- Pb < 1000 ppm
- Hg < 1000 ppm
- Cr +6 < 1000 ppm
- PBDE < 1000 ppm
- PBB < 1000 ppm

## 14. PRECAUTIONS FOR USE

### 14.1. Safety

- (1) Do not swallow any liquid crystal, even if there is no proof that liquid crystal is poisonous.
- (2) If the LCD panel breaks, be careful not to get liquid crystal to touch your skin.
- (3) If skin is exposed to liquid crystal, wash the area thoroughly with alcohol or soap.

### 14.2. Storage Conditions

- (1) Store the panel or module in a dark place where the temperature is  $23\pm 5^{\circ}\text{C}$  and the humidity is below  $50\pm 20\% \text{RH}$ .
- (2) Store in anti-static electricity container.
- (3) Store in clean environment, free from dust, active gas, and solvent.
- (4) Do not place the module near organics solvents or corrosive gases.
- (5) Do not crush, shake, or jolt the module.
- (6) Do not exposed to direct sun light of fluorescent lamps.

### 14.3. Installing LCD Module

Attend to the following items when installing the LCM.

- (1) Cover the surface with a transparent protective plate or touch panel to protect the polarizer and LC cell.
- (2) When assembling the LCM into other equipment, the spacer to the bit between the LCM and the fitting plate should have enough height to avoid causing stress to the module surface, refer to the individual specifications for measurements. The measurement tolerance should be  $\pm 0.1 \text{mm}$ .



#### 14.4. Precautions For Operation

- (1) Viewing angle varies with the change of liquid crystal driving voltage ( $V_o$ ). Adjust  $V_o$  to show the best contrast.
- (2) Driving the LCD in the voltage above the limit will shorten its lifetime.
- (3) Response time is greatly delayed at temperature below the operating temperature range. However, this does not mean the LCD will be out of the order. It will recover when it returns to the specified temperature range.
- (4) When turning the power on, input each signal after the positive/negative voltage becomes stable.
- (5) Do not apply water or any liquid on product which composed of T/P.

#### 14.5. Handling Precautions

- (1) Avoid static electricity which can damage the CMOS LSI; please wear the wrist strap when handling.
- (2) The polarizing plate of the display is very fragile. so, please handle it very carefully.
- (3) Do not give external shock.
- (4) Do not apply excessive force on the surface; it may cause display abnormal .
- (5) Do not wipe the polarizing plate with a dry cloth, as it may easily scratch the surface of plate.
- (6) Do not use ketonics solvent & Aromatic solvent, use with a soft cloth soaked with a cleaning naphtha solvent.
- (7) Do not operate it above the absolute maximum rating.
- (8) Do not remove the panel or frame from the module.
- (9) Do not apply water or any liquid on product, which composed of T/P.

#### 14.6. Warranty

- (1) The period is within 12 months since the date of shipping out under normal using and storage conditions.
- (2) The warranty will be avoided in case of defect induced by customer.

## 15.FACTORY

For the consideration of mass production convenience, this model will be manufactured in the factories listed below.

FACTORY NAME: GIANTPLUS TECHNOLOGY CO., LTD  
 FACTORY ADDRESS: 15 Industrial Rd., Lu-Chu Li, Toufen Town  
 351 Miao-Li County, Taiwan, R.O.C..  
 FACTORY PHONE: TEL: 886-37-611-611 FAX: 886-37-613-166

FACTORY NAME: KUNSHAN GIANTPLUS OPTOELECTRONICS  
 TECHNOLOGY CO., LTD.  
 FACTORY ADDRESS: KunShan City, JiangShu Province, China.  
 FACTORY PHONE: TEL:86-512-57780-988 FAX : 86-512-57780-503

FACTORY NAME: SHENZHEN GIANTPLUS OPTOELEC. DISPLAY CO., LTD.  
 FACTORY ADDRESS: Building A, Distict A ,MinZhu99 Industrial City,  
 ShaJing Industrial Park, BaoAn District, ShenZhen, China  
 FACTORY PHONE: TEL: 86-755-29720-088 FAX : 86-755-29720-828

## 16.REVISION HISTORY

Version	Revise record	Date
A	New version	2008/7/16
C	1.Modify color data Assignment -> P12	2008/9/8
	2.Addition note2 for Brightness data.	
C1	1.Modify TFT LCD Characetristic -> P.8	2008/9/22